



Food Preparation

HOBART



MIXER

H600 / 800

Spare Parts
Pièces Détachées
Ersatzteile
Onderdelen

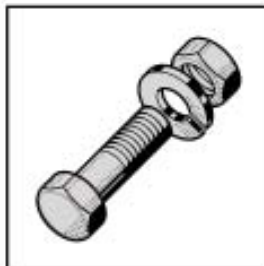

This document is the property of Hobart Manufacturing. Reproduction of this document is prohibited without the written consent of Hobart Manufacturing.

Base and Pedestal Unit.....	2
Base et Colonne	
Gehäuse mit standfüßen	
Transmission Case Unit.....	3
bolte de Vitesses	
Antriebsgehäuse	
Bowl Support and Bowl lift.....	4 / 5
Support et Relevage de bol	
Kesselheber und Haalterung	
Power Bowl Lift.....	6
Relevage Automatique de Bol	
Automatischer Kesselhub	
Attachment Hub.....	7
Cannon port-accessoires	
Ansatznabe	
Shifting Unit.....	8
Changement de Vitesses	
Geschwindig Keitswahlschalter	
Planetary Shaft.....	9
Planétaire arbe	
Planetengetriebewelle	
Clutch Shaft.....	10
Arbe des clabots	
Kupplungswelle	
Worm Gear Shaft.....	11
Arbre roue hélicoidal	
Schneckenradwelle	
Planetary.....	12
Planétaire	
Planetengezriebe	
Guard Assembly.....	13
Sécurité de bol	
Schutzgitter	
Guard Assembly 2000.....	14
Sécurité de bol 2000	
Schutzgitter 2000	
Motor.....	15
Moteur	
Motor	
Timer.....	16
Minuterie	
Zeitschater	
Electrics.....	17 / 18
Électriques	
Elektrik	
Bowl and Equipment.....	19
Bol et Équipement	
Kessel und Ausrüstung	
Agitators.....	20
Agitateurs	
Rührwerkzeige	

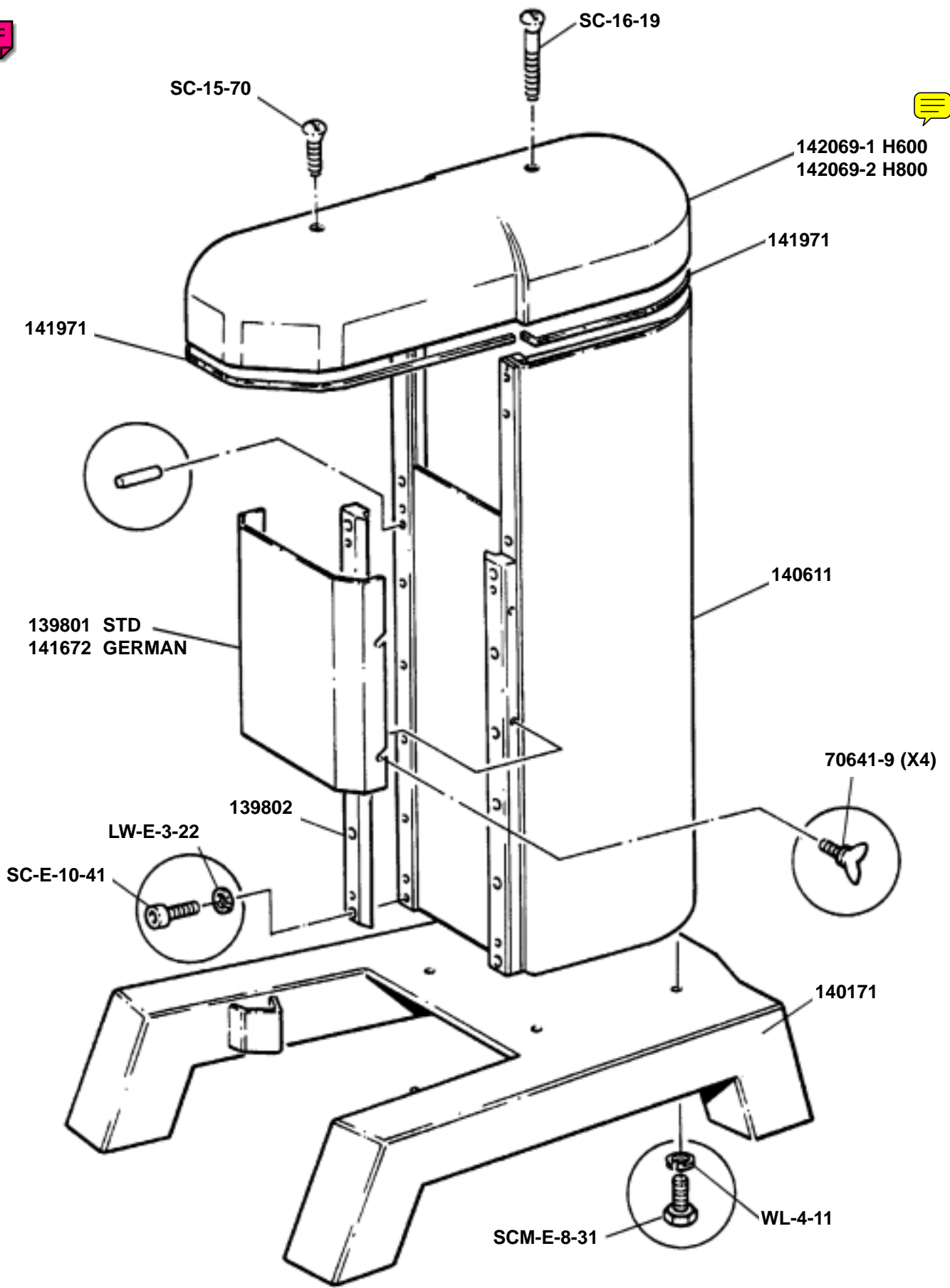

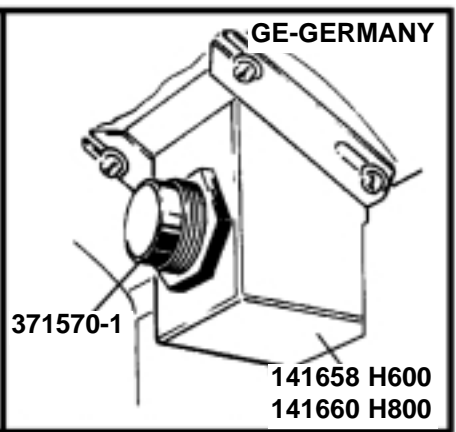
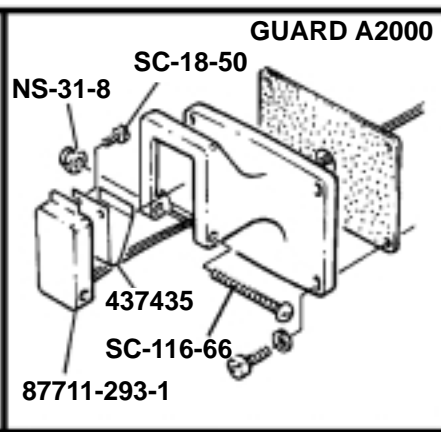
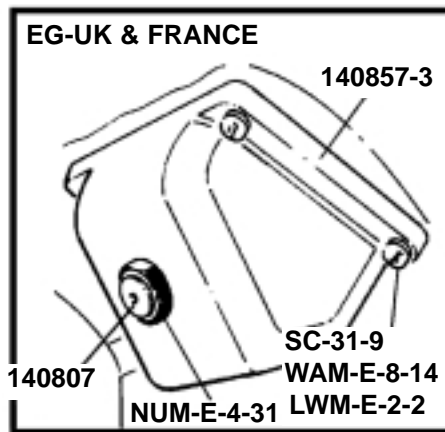
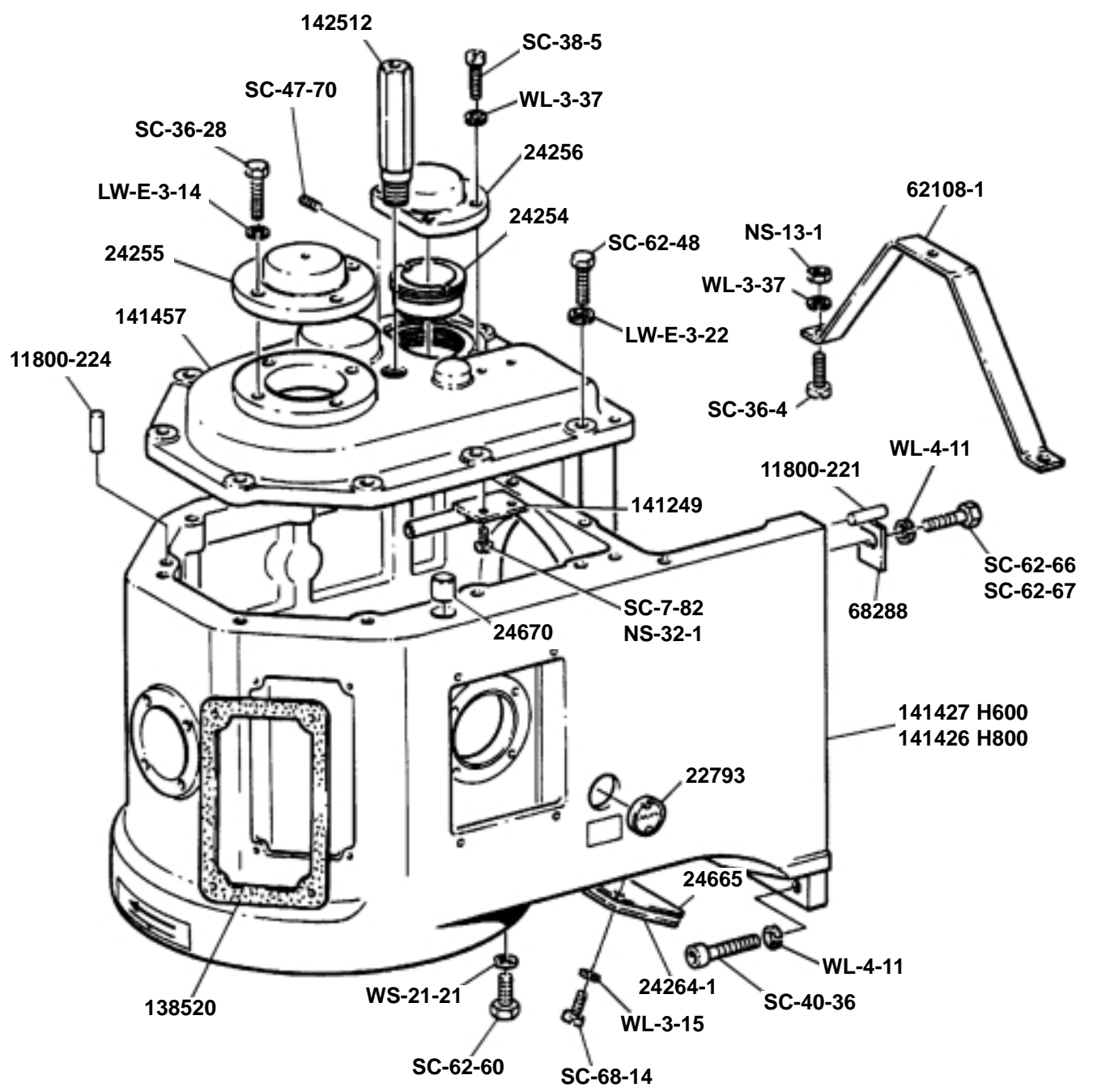

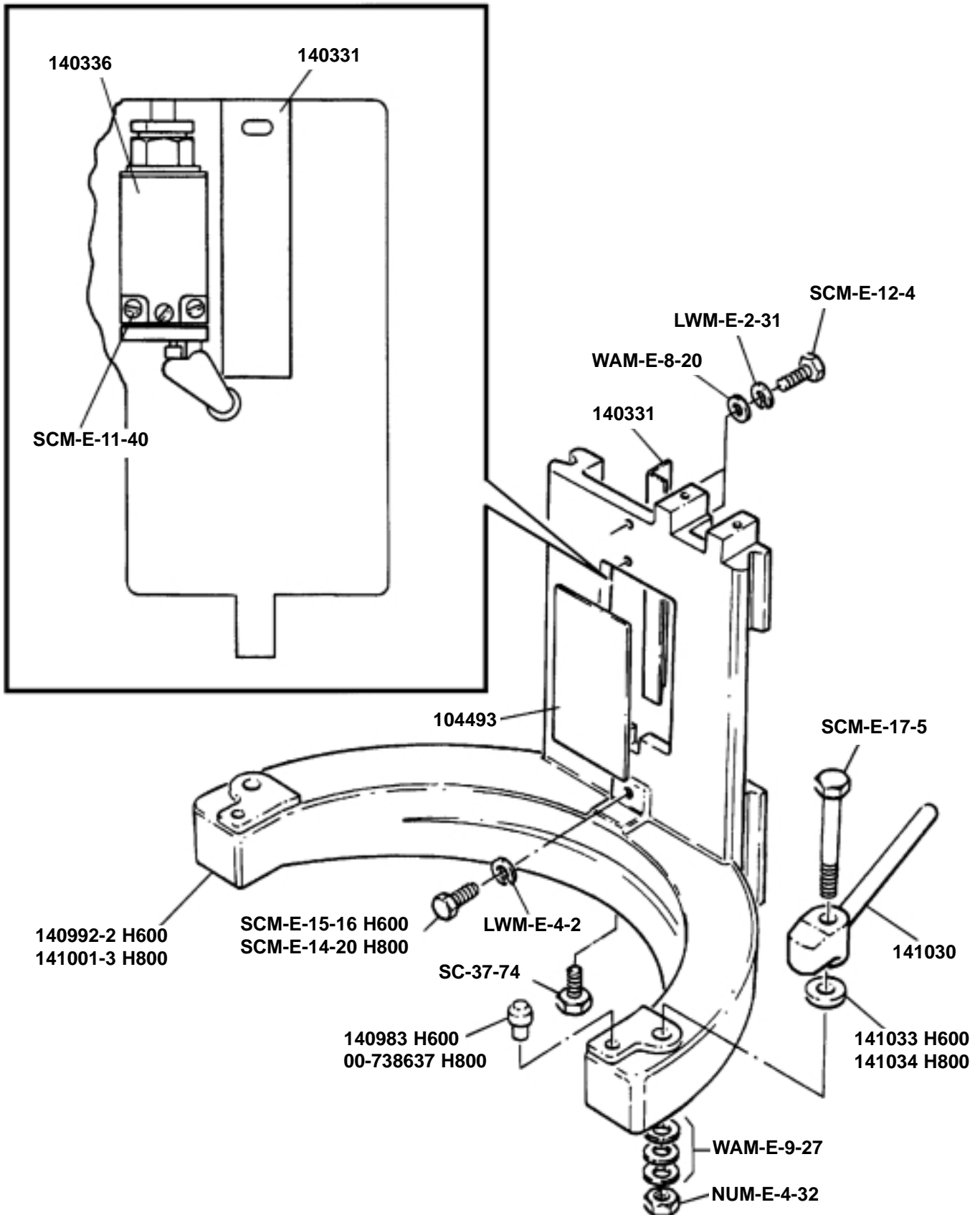

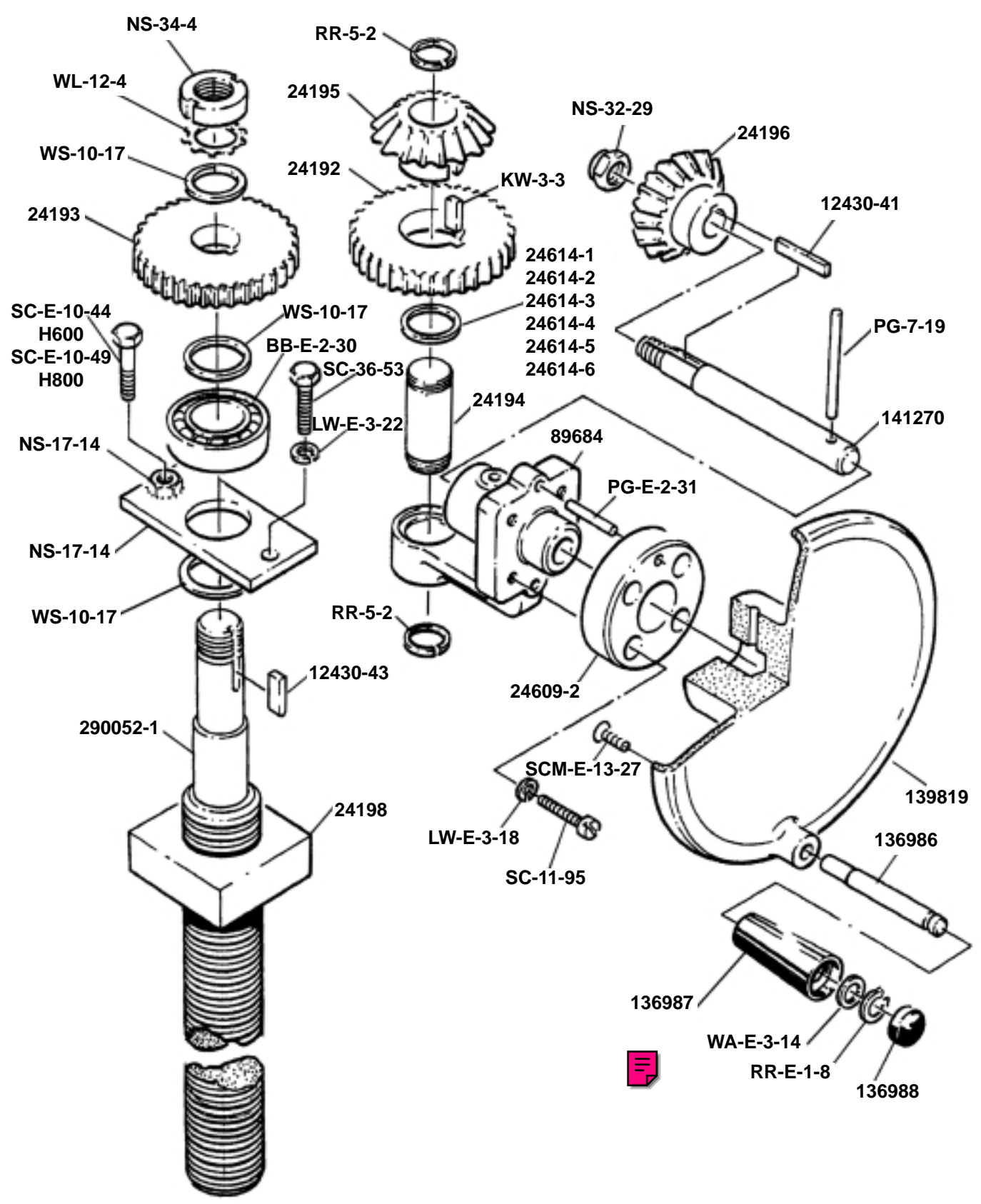

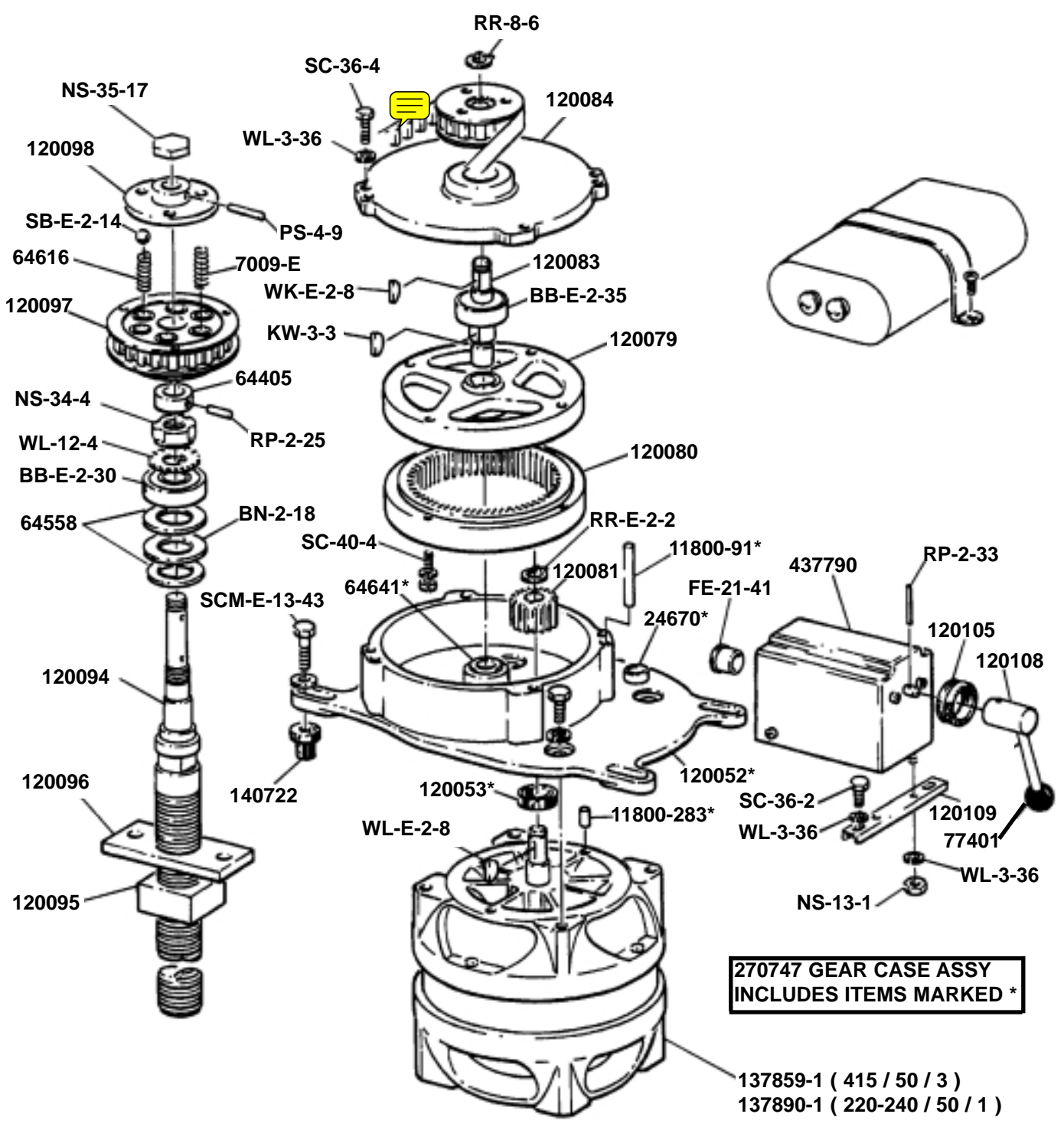

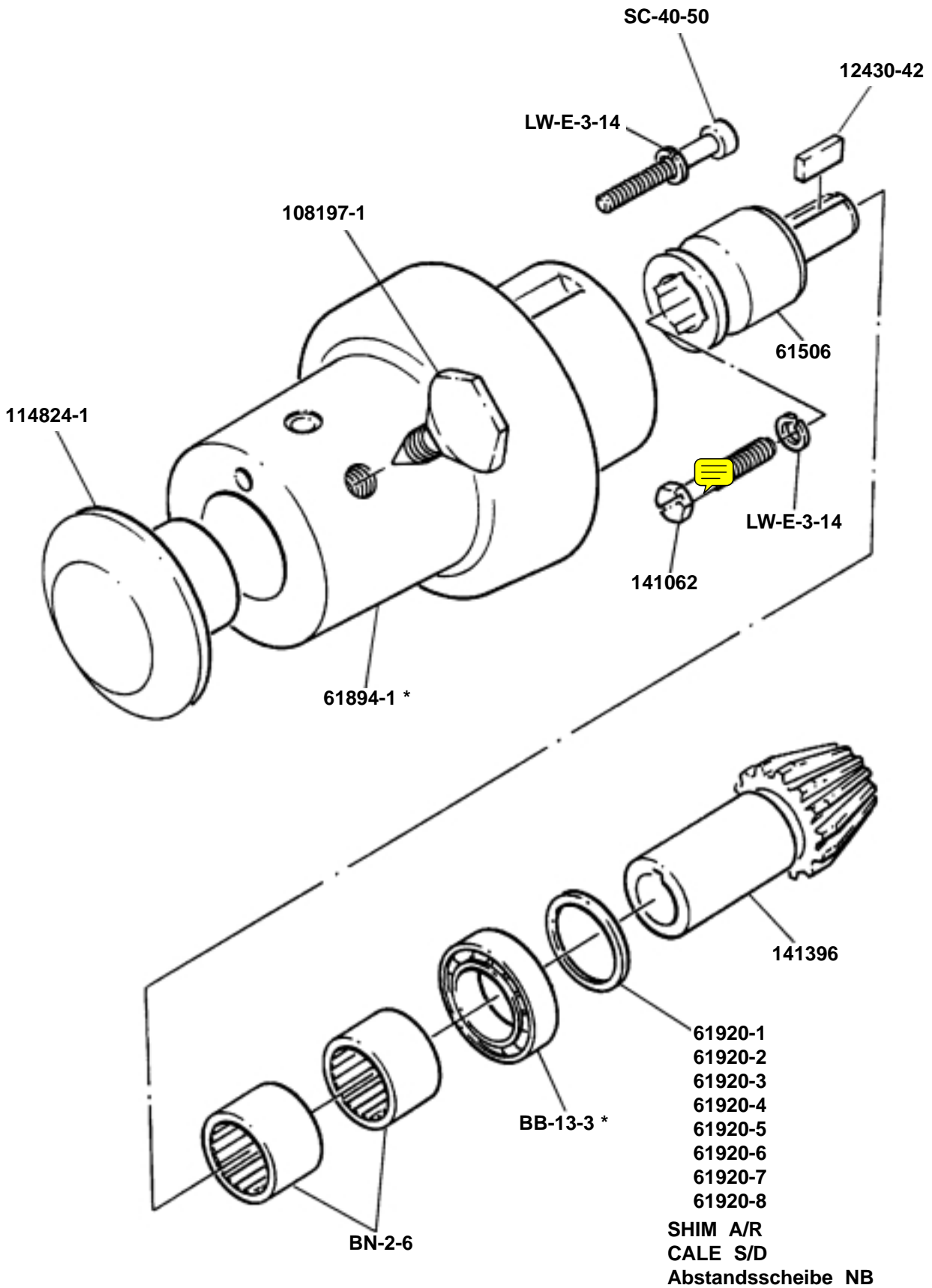

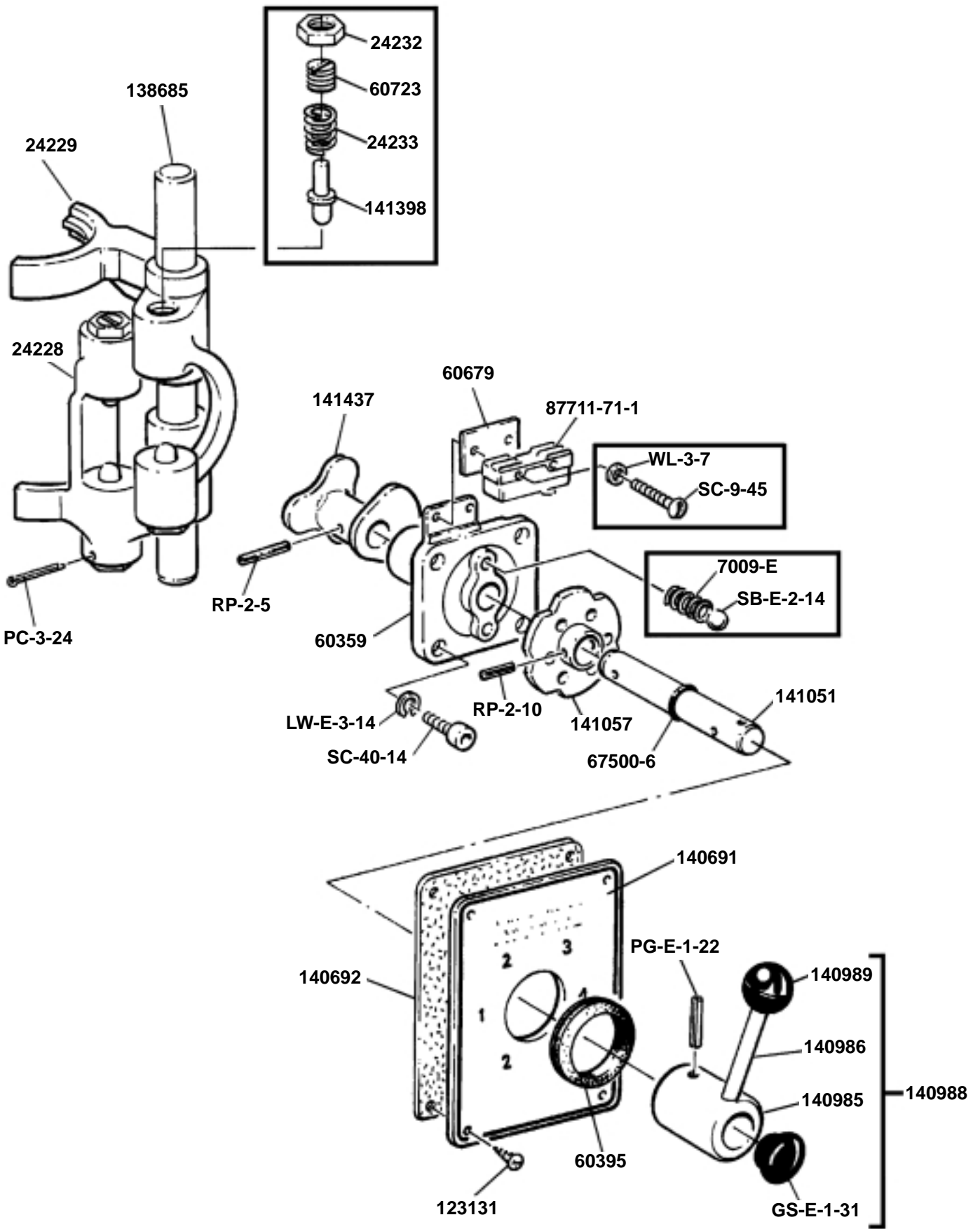

- 24226-4 .150"
- 24226-5 .153"
- 24226-6 .156"
- 24226-7 .159"
- 24226-8 .162"
- 24226-9 .165"
- 24226-11 .168"
- 24226-12 .174"
- SHIMS - A/R

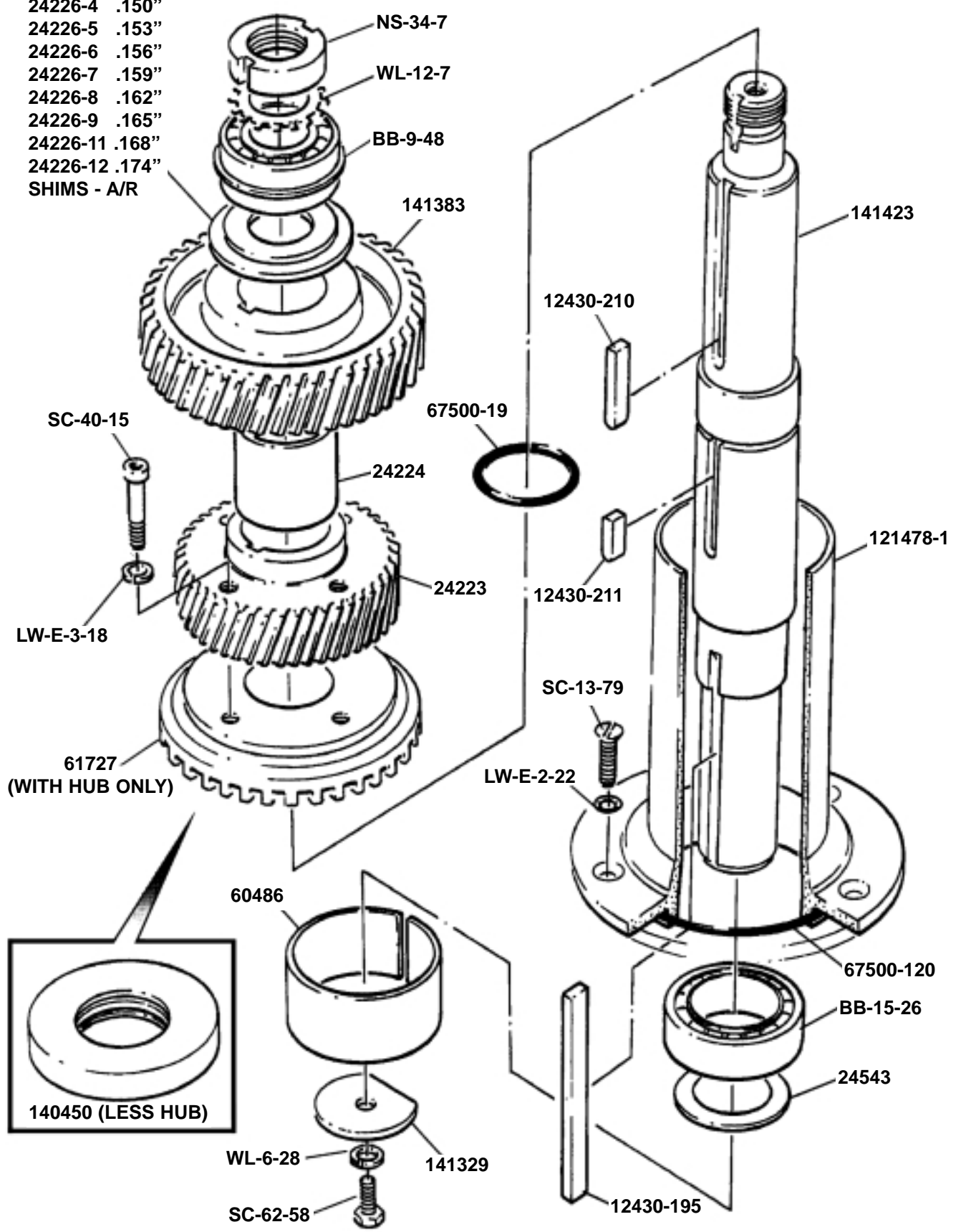

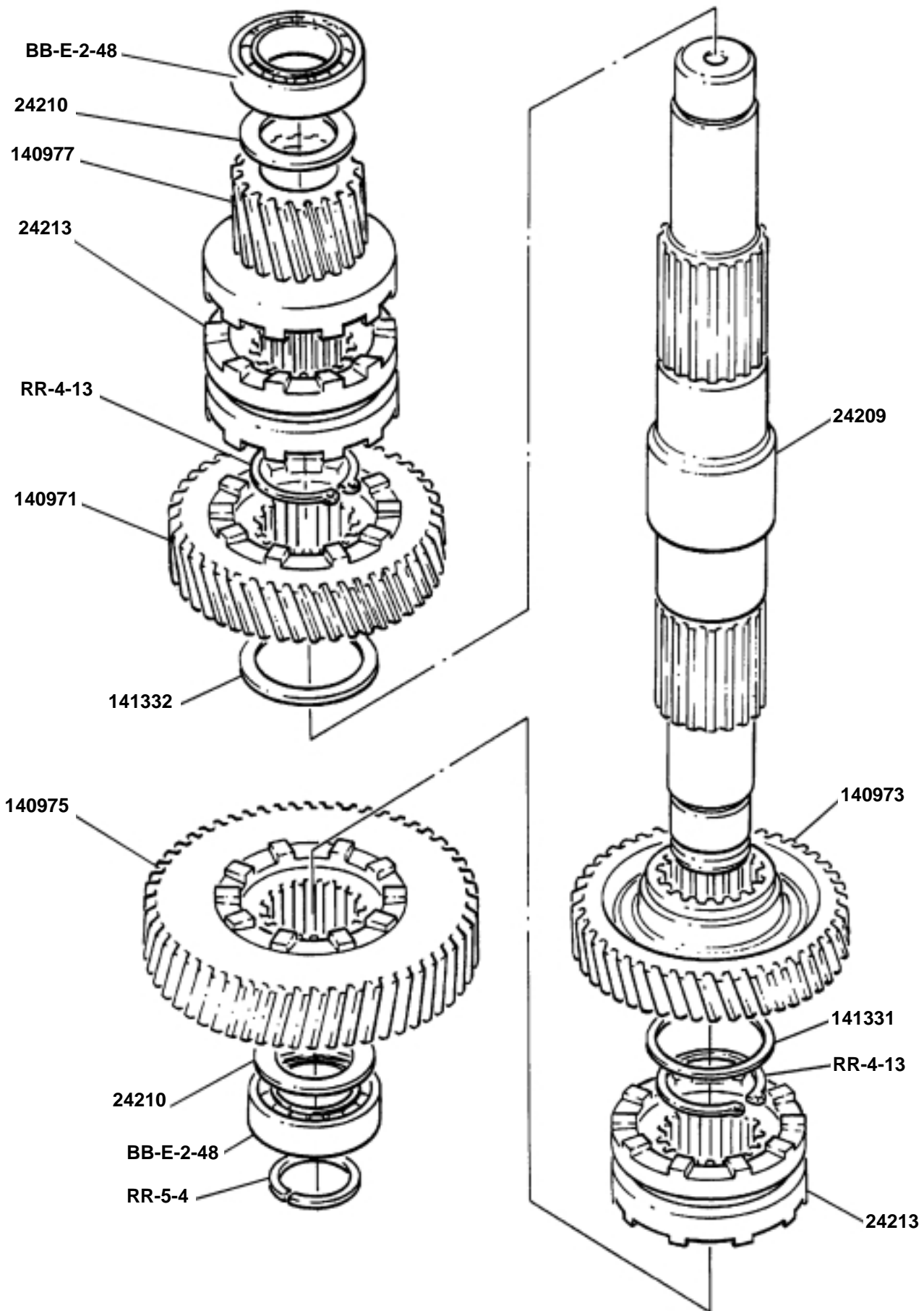

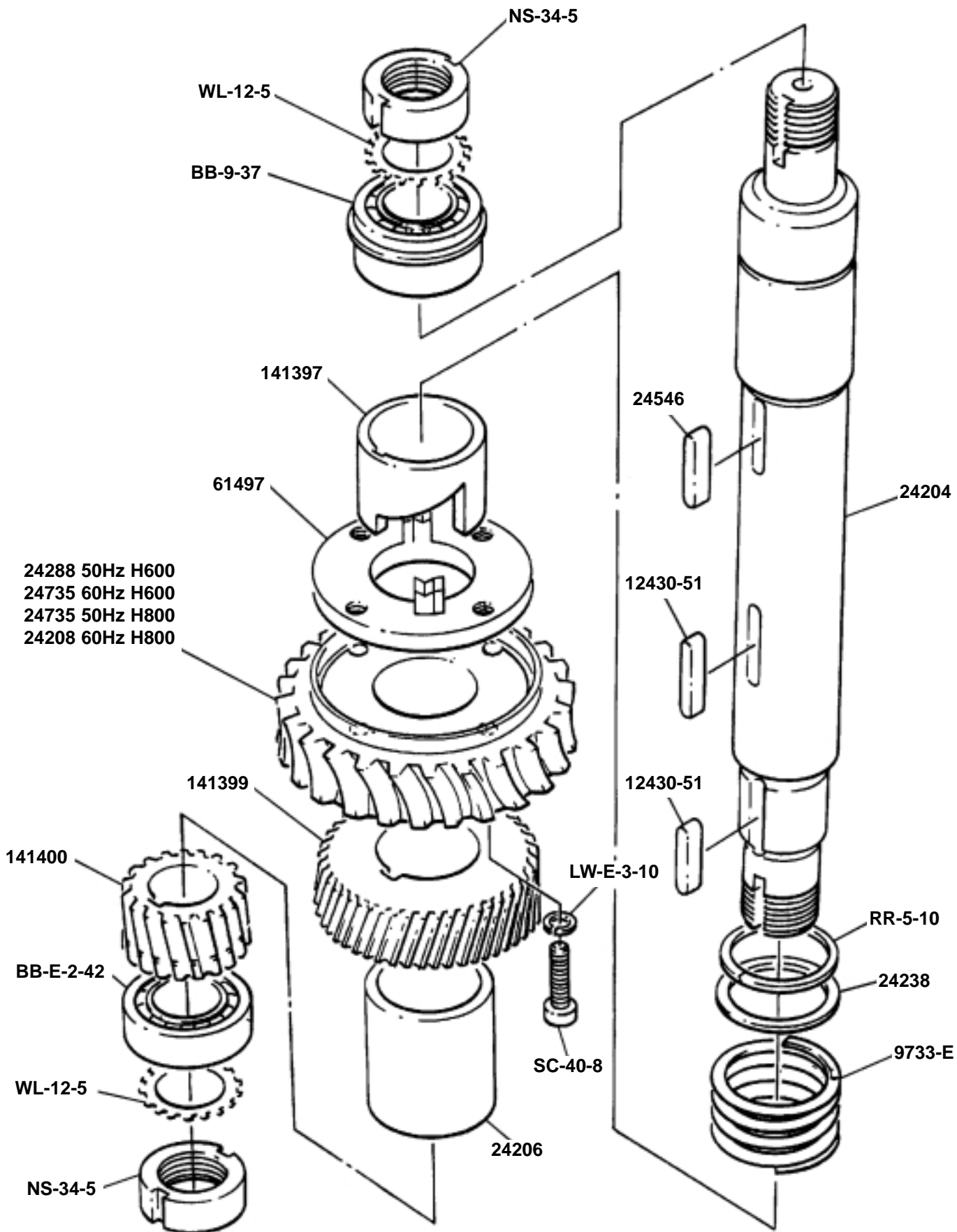

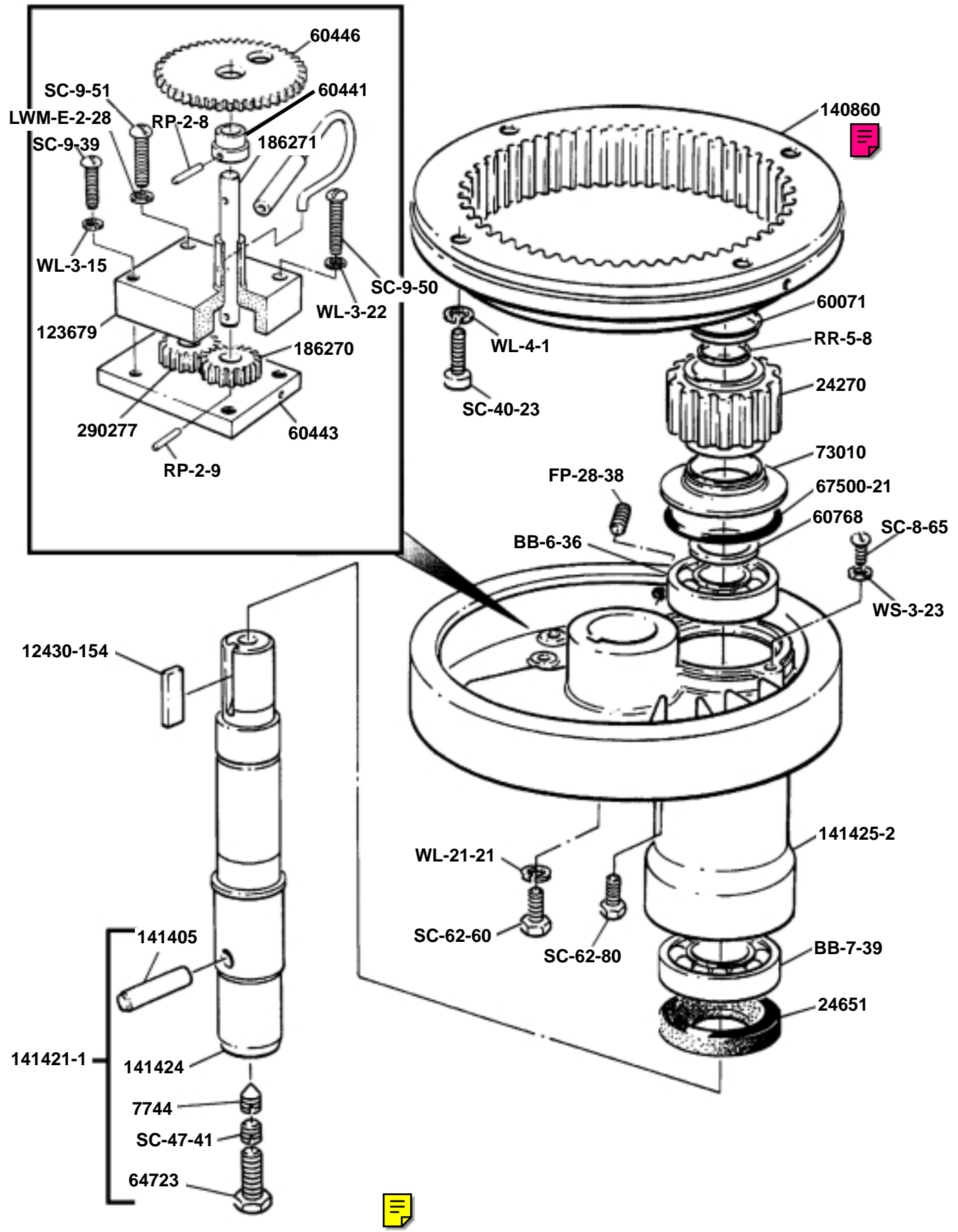

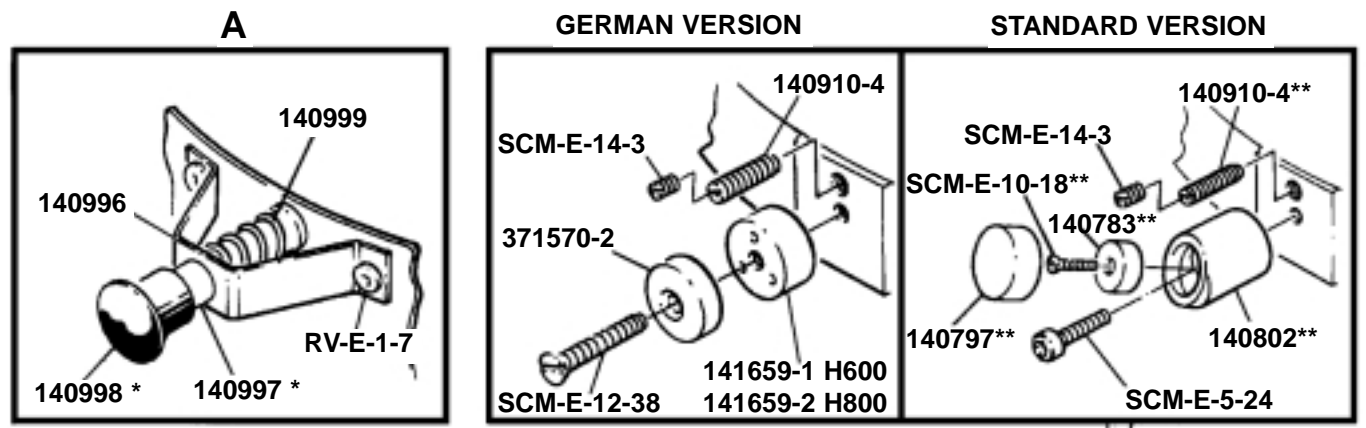

STD = STANDARD VERSION
GE = GERMAN VERSION

- 141611-1** .12mm
- 141611-2** .25mm
- 141611-3** .37mm
- SHIMS A/R

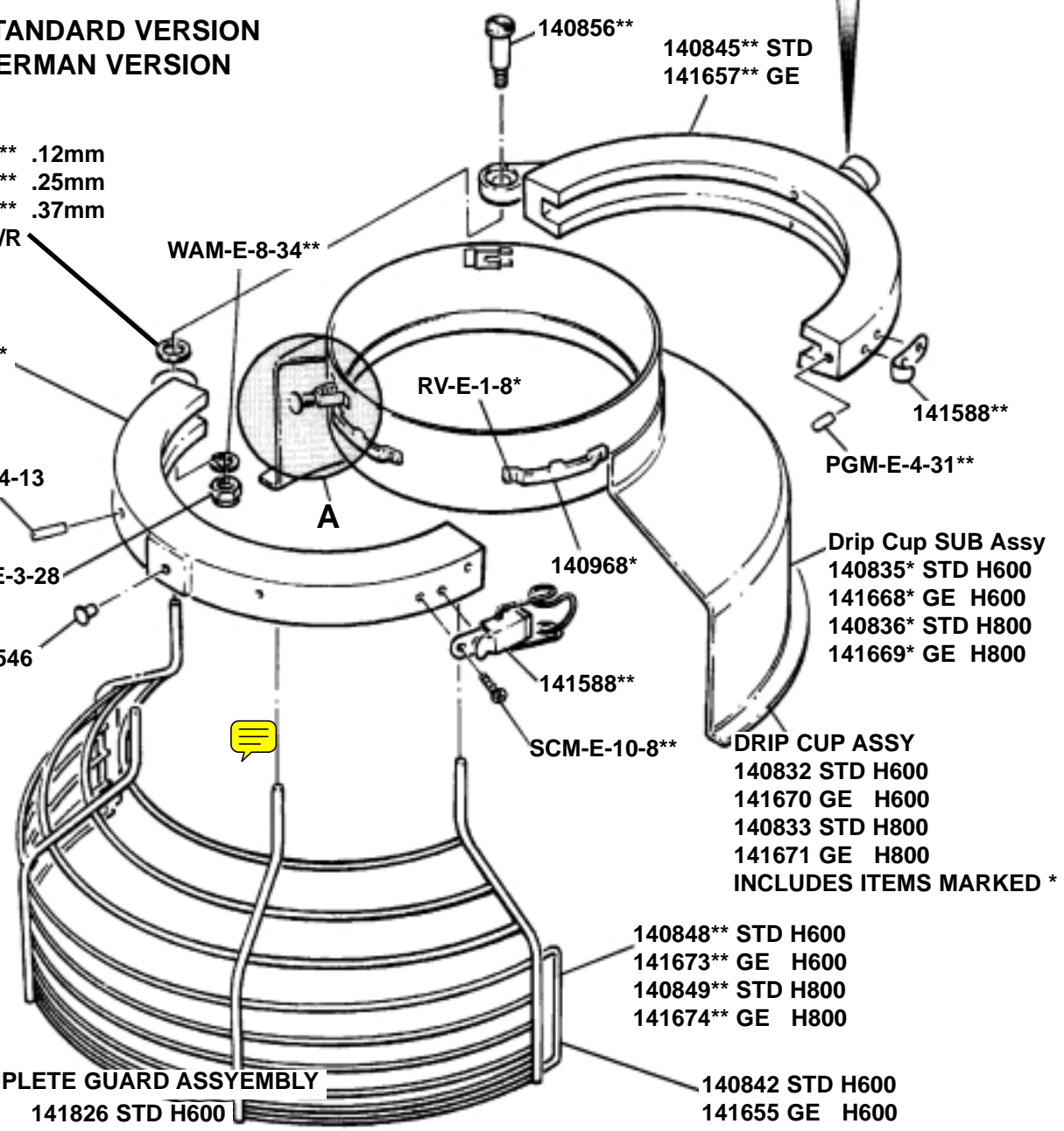

- COMPLETE GUARD ASSYMBLY**
- 141826 STD H600
 - 141828 GE H600
 - 141827 STD H800
 - 141829 GE H800

- 140832 STD H600
- 141670 GE H600
- 140833 STD H800
- 141671 GE H800
- INCLUDES ITEMS MARKED *
- 140848** STD H600
- 141673** GE H600
- 140849** STD H800
- 141674** GE H800
- 140842 STD H600
- 141655 GE H600
- 140843 STD H800
- 141671 GE H800
- INCLUDES ITEMS MARKED**

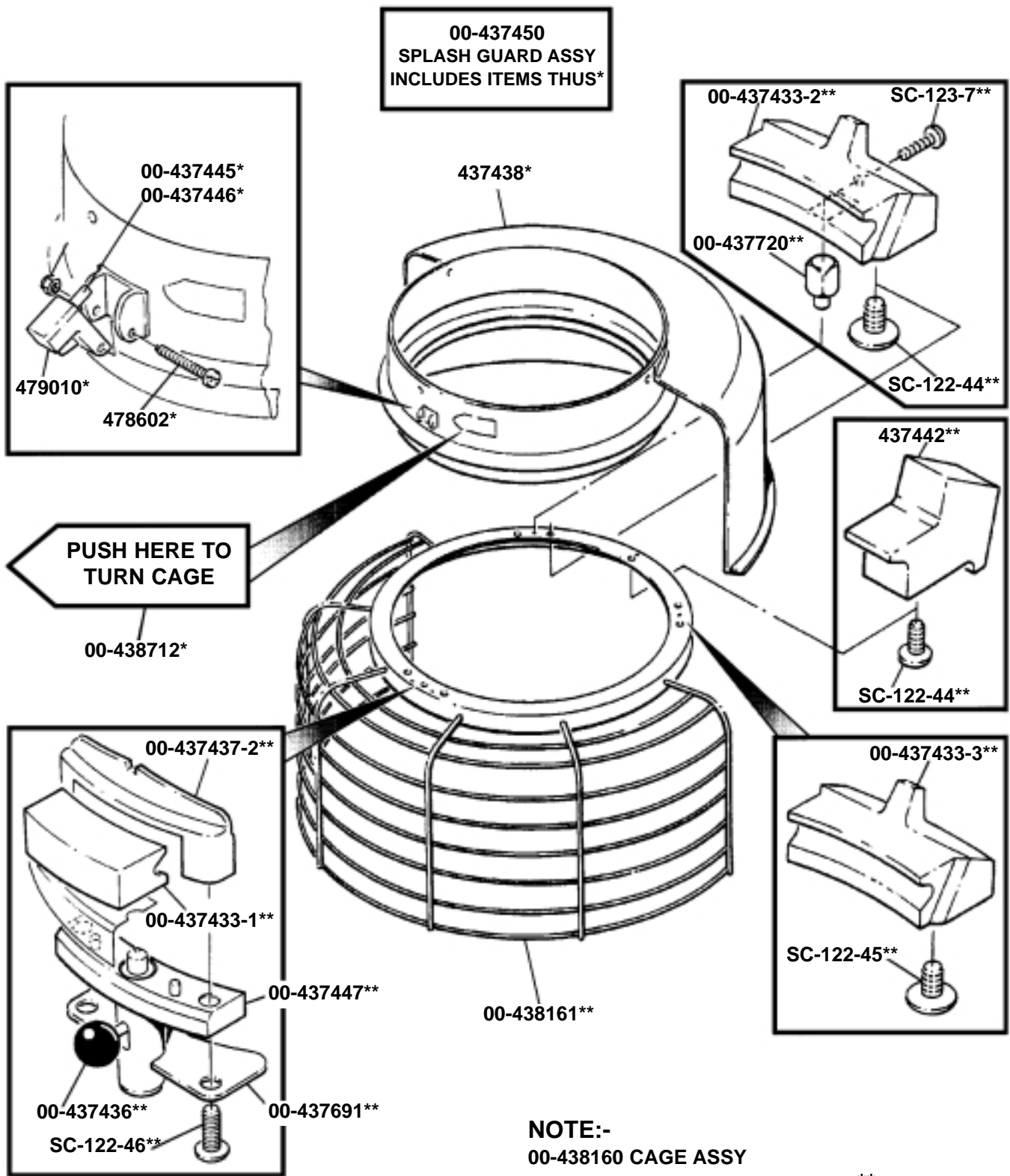



137416-1 (230/50/1) H600
 137415-1 (400/50/3) H600

 141435-1 (230/50/1) H800
 139360-1 (400/50/3) H800

291457-2 (50Hz)
 291457-1 (60Hz)

67500-24
 RP-2-4
 PG-E-2-31

24291 (50Hz) H600
 24298 (60Hz) H600

.....
 24298 (50Hz) H800
 ? (60Hz) H800

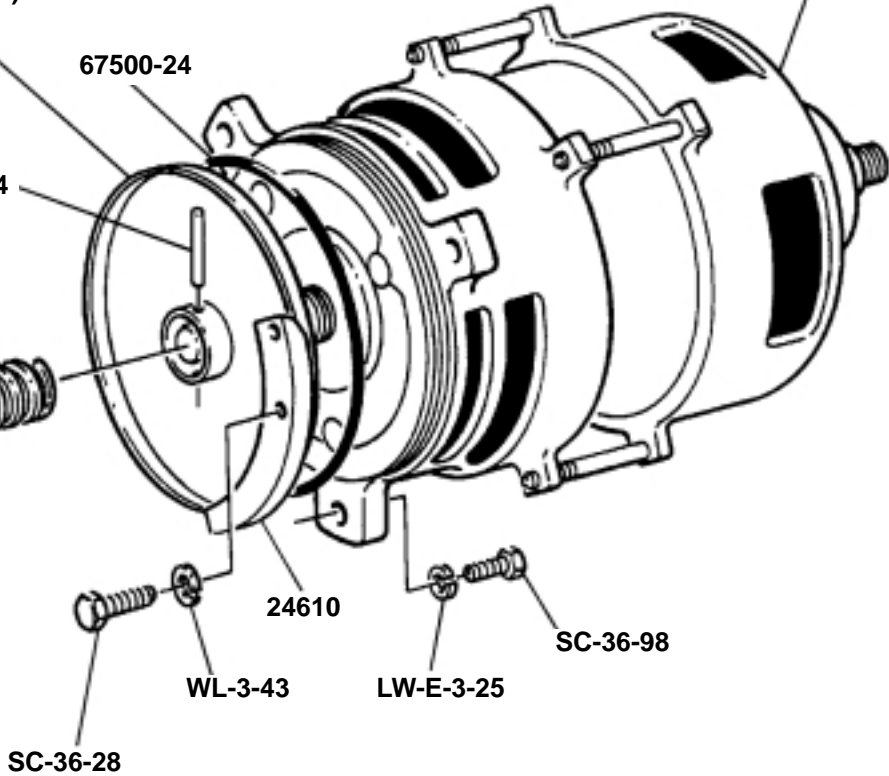

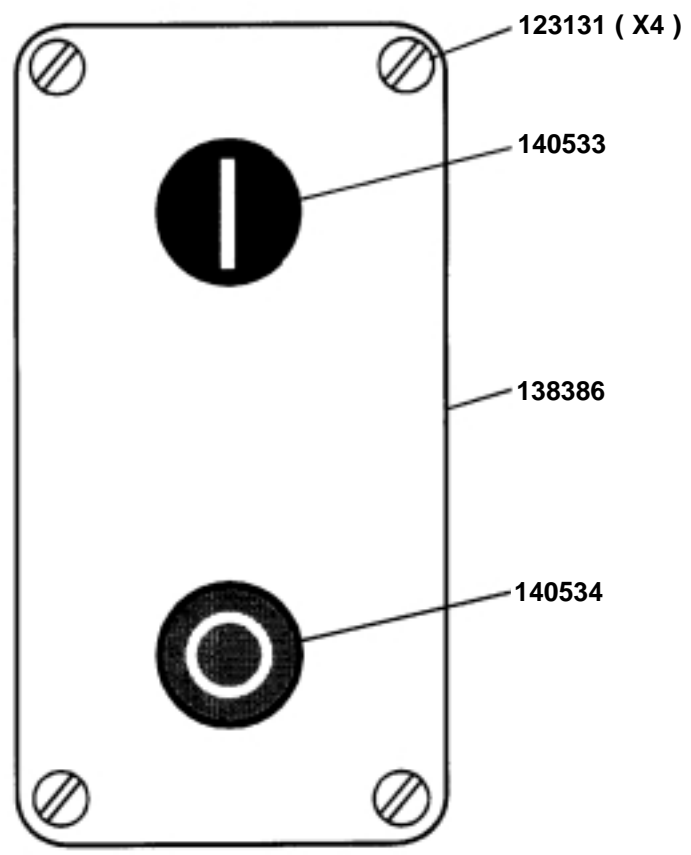

Timer / Minuterie / Zeitschater	
15 min	SS-E-18-10
30 min	SS-E-18-11

Plate Timer / Plaque minuterie Zeitschaterplatte	
15 min	139396
30 min	139869

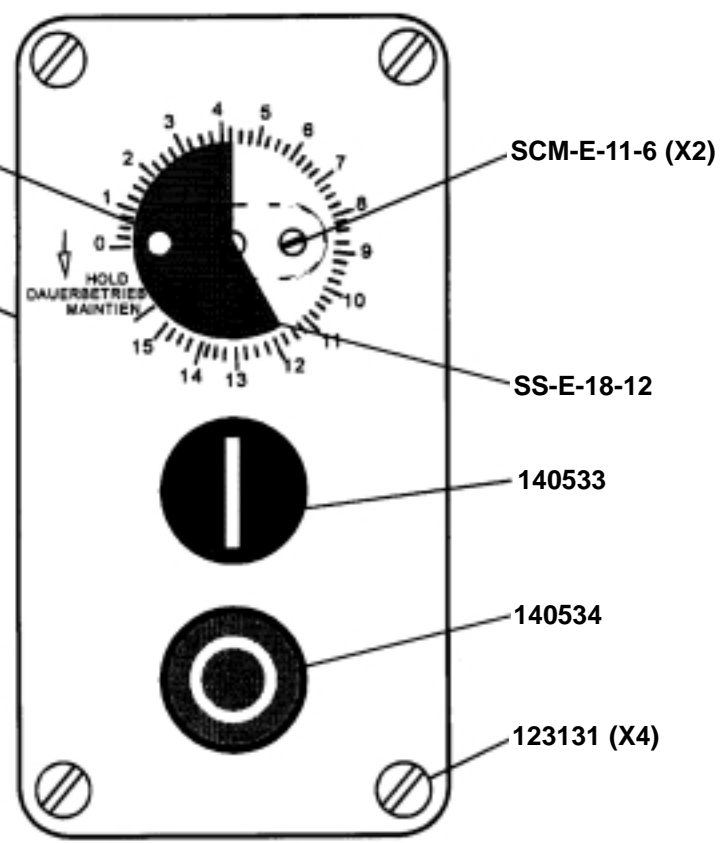

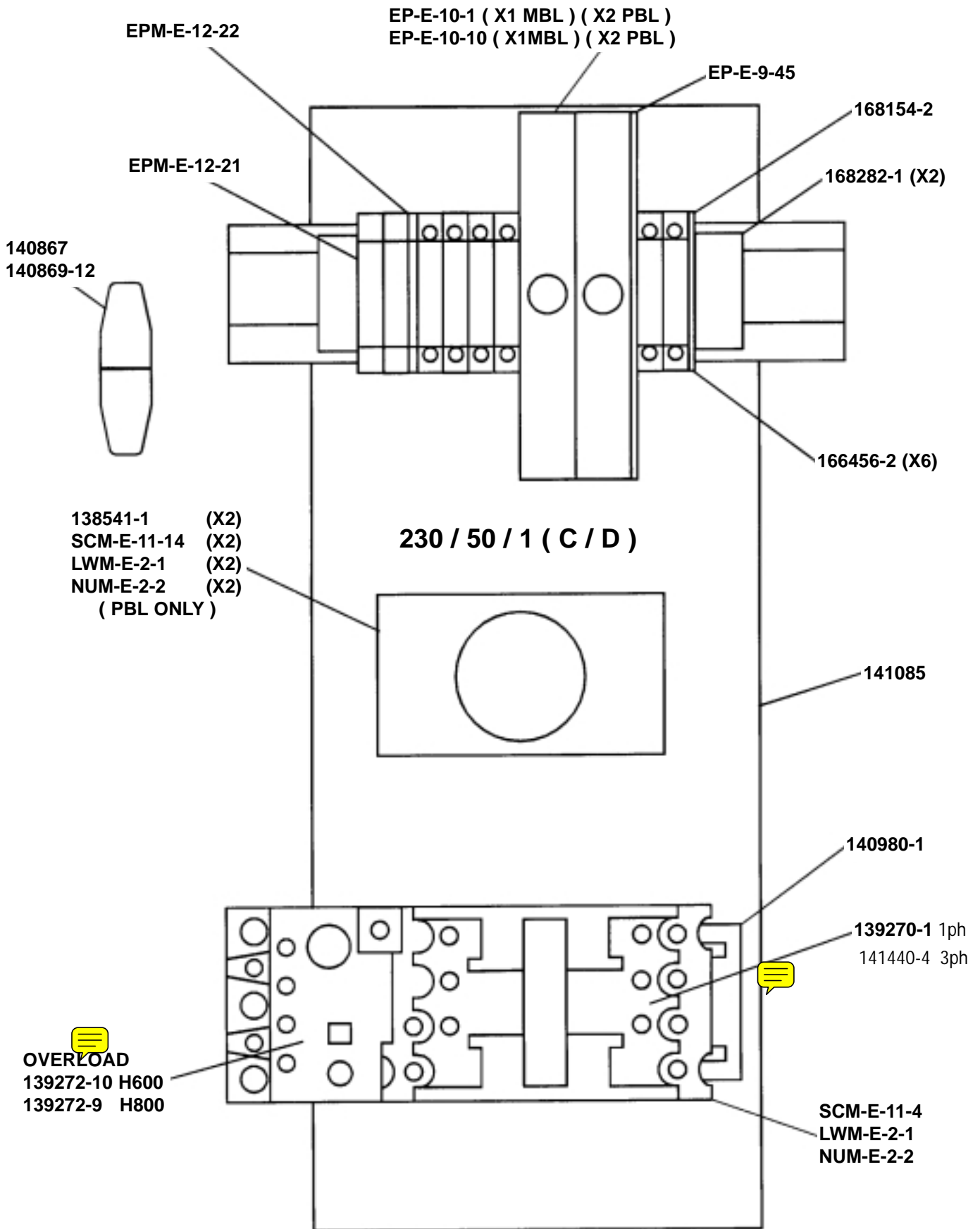

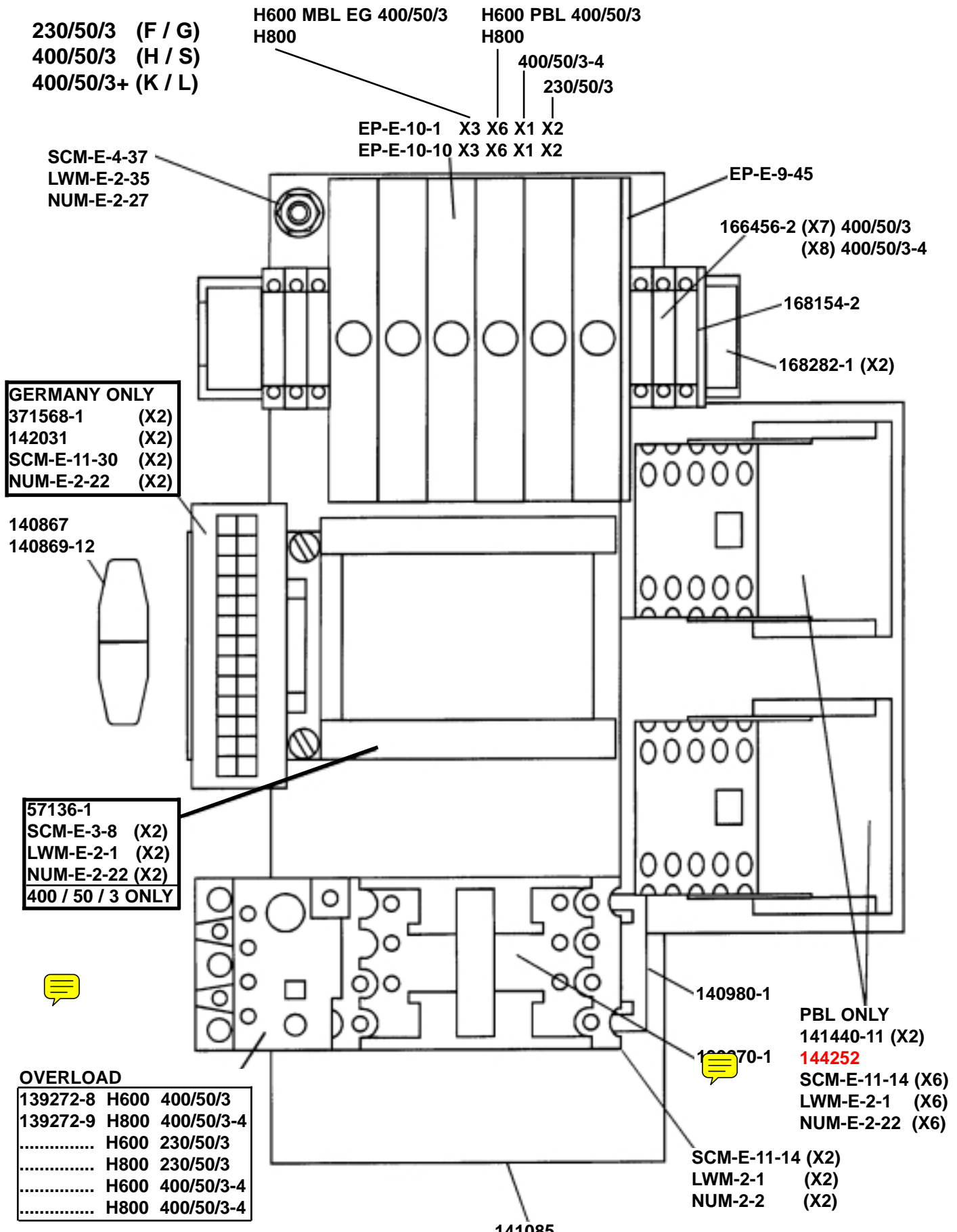

- 295648 30qt S/S BOWL H600
- 295650 40qt BOWL H600
- 275686 40qt S/S BOWL H600
- 275686 40qt S/S BOWL H800
- 66462 60qt S/S BOWL H600
- 59780 80qt S/S BOWL H800

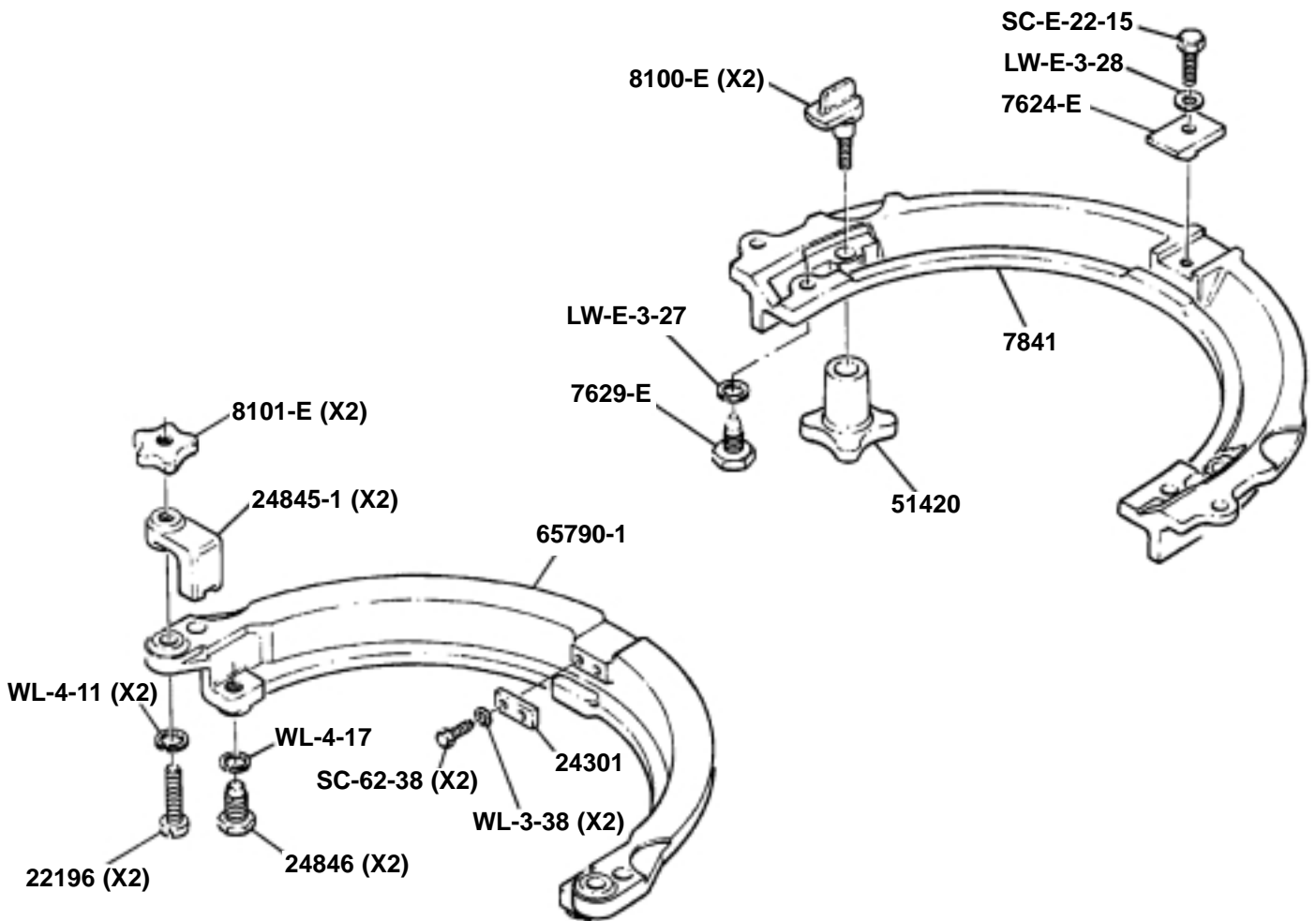
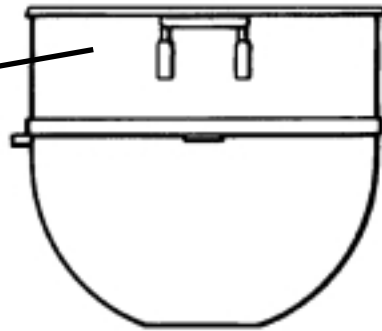



PASTRY KNIFE
H600
275972 30qt PK
68096 60qt PK

H800
52396 80qt PK



M & 'EB' HOOKS
H600
295176 40qt EB

H800
8151-E 40qt M
8152-E 80qt M
55664 80qt M S/STEEL



HOOK 'ED'
H600
141430 60qt ED

H800
141431 80qt ED



'C' WING WHIP
H600
295159 40qt
295156 60qt

H800
53339 80qt



'D' WHIP
295031 30qt
9006-E 40qt
24900-2 60qt

H800
9006-E 40qt
52912 80qt



'B' BEATER
H600
275809 30qt
12108-E 40qt
55662 40qt S/STEEL
141429-1 60qt
141429-2 60qt S/STEEL

H800
12108-E 40qt
55662 40qt S/STEEL
52312 80qt
53309 80qt S/STEEL

NOTE;-
737420 (BOWL TRUCK H600 & H800)



As continued product improvements is a policy of HOBART, specifications are subject to change without notice.

Ce catalogue n'est pas contractuel, HOBART se réserve le droit, et sans préavis, d'apporter toutes modifications ou améliorations à ses matériels,

HOBART behält sich das Recht vor, an allen Produkten technische Änderungen und Verbesserungen ohne Ankündigung vorzunehmen,

Voortdurende produktverbetering vormt een wezenlijk onderdeel van het beleid van HOBART. Specificaties kunnen zonder kennisgeving gewijzigd worden.

PLE-200402-A-05-00



Food Preparation

HOBART



MIXER

H600 / 800

Spare Parts
Pièces Détachées
Ersatzteile
Onderdelen

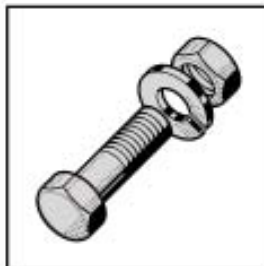

This document is the property of Hobart Manufacturing. Reproduction of this document is prohibited without the written consent of Hobart Manufacturing.

	Page
Base and Pedestal Unit.....	3
Base et Colonne	
Gehäuse mit standfüßen	
Transmission Case Unit.....	4
bolte de Vitesses	
Antriebsgehäuse	
Bowl Support and Bow lift.....	5 / 6
Support et relevage de bol	
Kesselheber und Haalterung	
Power Bowl Lift.....	7
Relevage Automatique de Bol	
Automatischer Kesselhub	
Attachment Hub.....	8
Cannon port-accessoires	
Ansatznabe	
Shifting Unit.....	9
Changement de Vitesses	
Geschwindig Keitswahlschalter	
Planetary Shaft.....	10
Planétaire arbe	
Planetengetriebewelle	
Clutch Shaft.....	11
Arbe des ciabots	
Kupplungswelle	
Worm Gear Shaft.....	12
Arbre roue hélicoidal	
Schneckenradwelle	
Planetary.....	13
Planétaire	
Planetengezriebe	
Guard Assembly.....	14
Sécurité de bol	
Schutzgitter	
Guard Assembly 2000.....	15
Sécurité de bol 2000	
Schutzgitter 2000	
Motor.....	16
Moteur	
Motor	
Timer.....	17
Minuterie	
Zeitschater	
Electrics.....	18 / 19
Électriques	
Elektrik	
Bowl and Equipment.....	20
Bol et Équipement	
Kessel und Ausrüstung	
Agitators.....	21
Agitateurs	
Rührwerkzeuge	

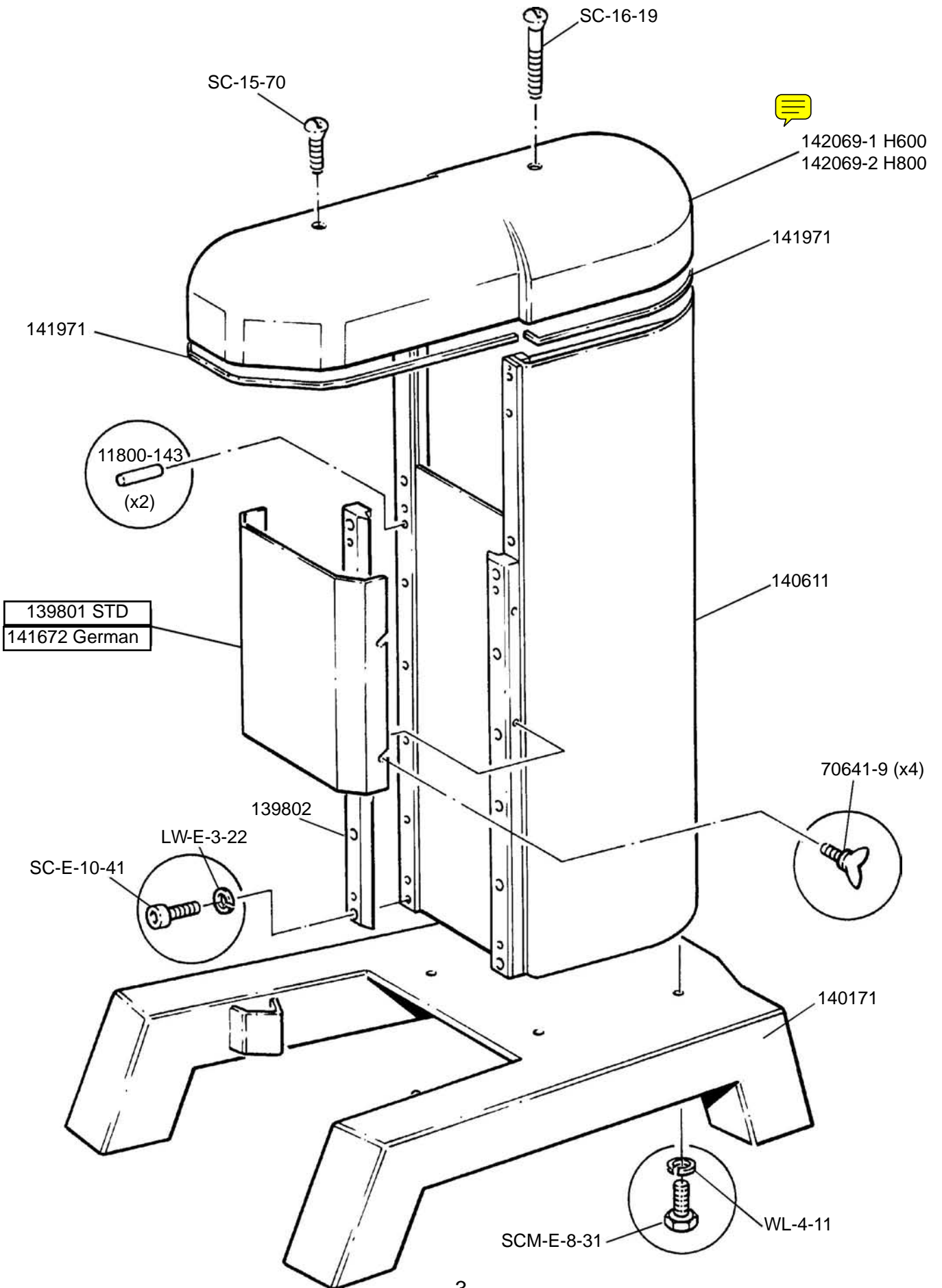

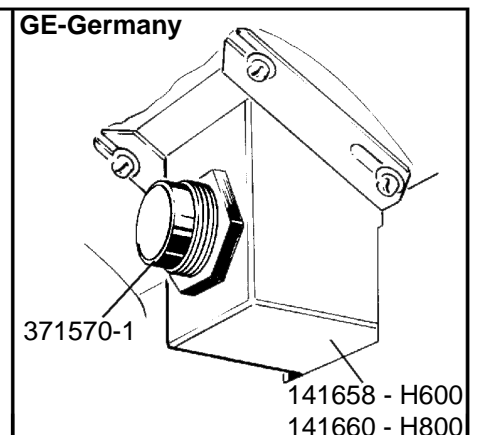
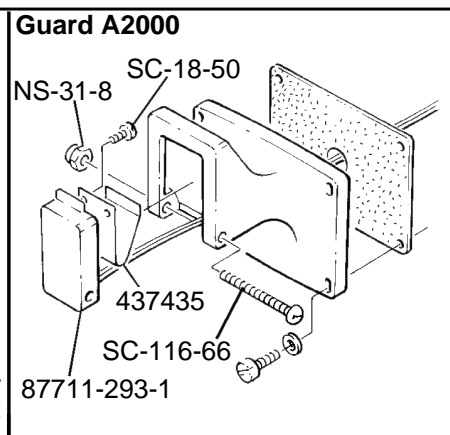
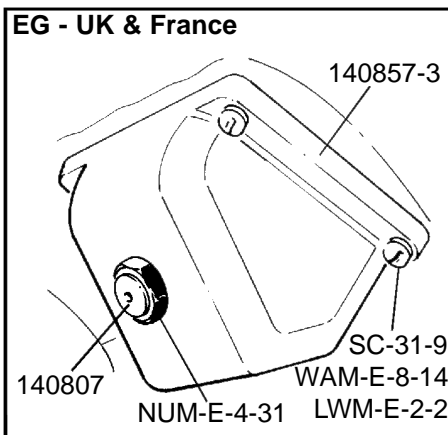
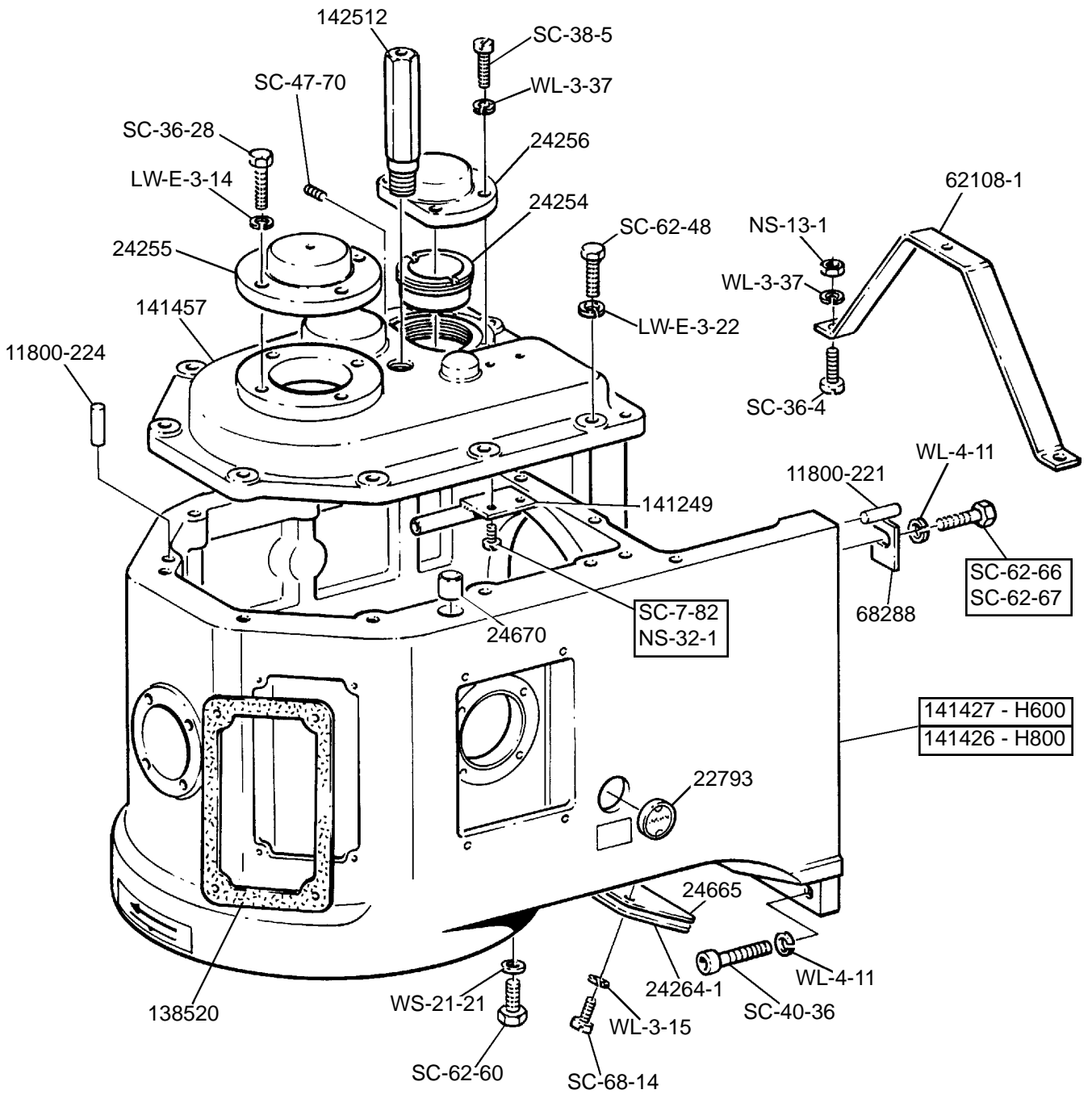

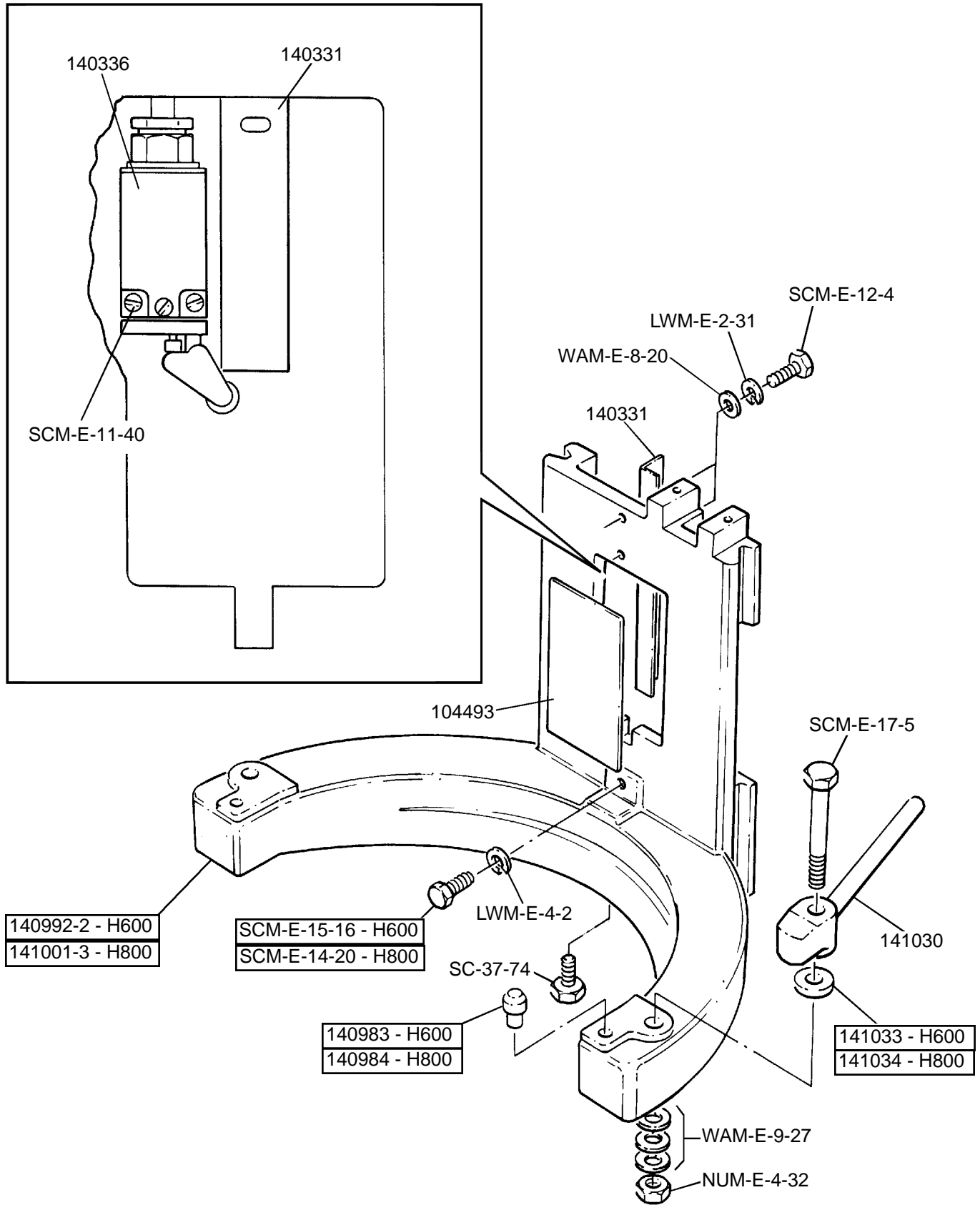

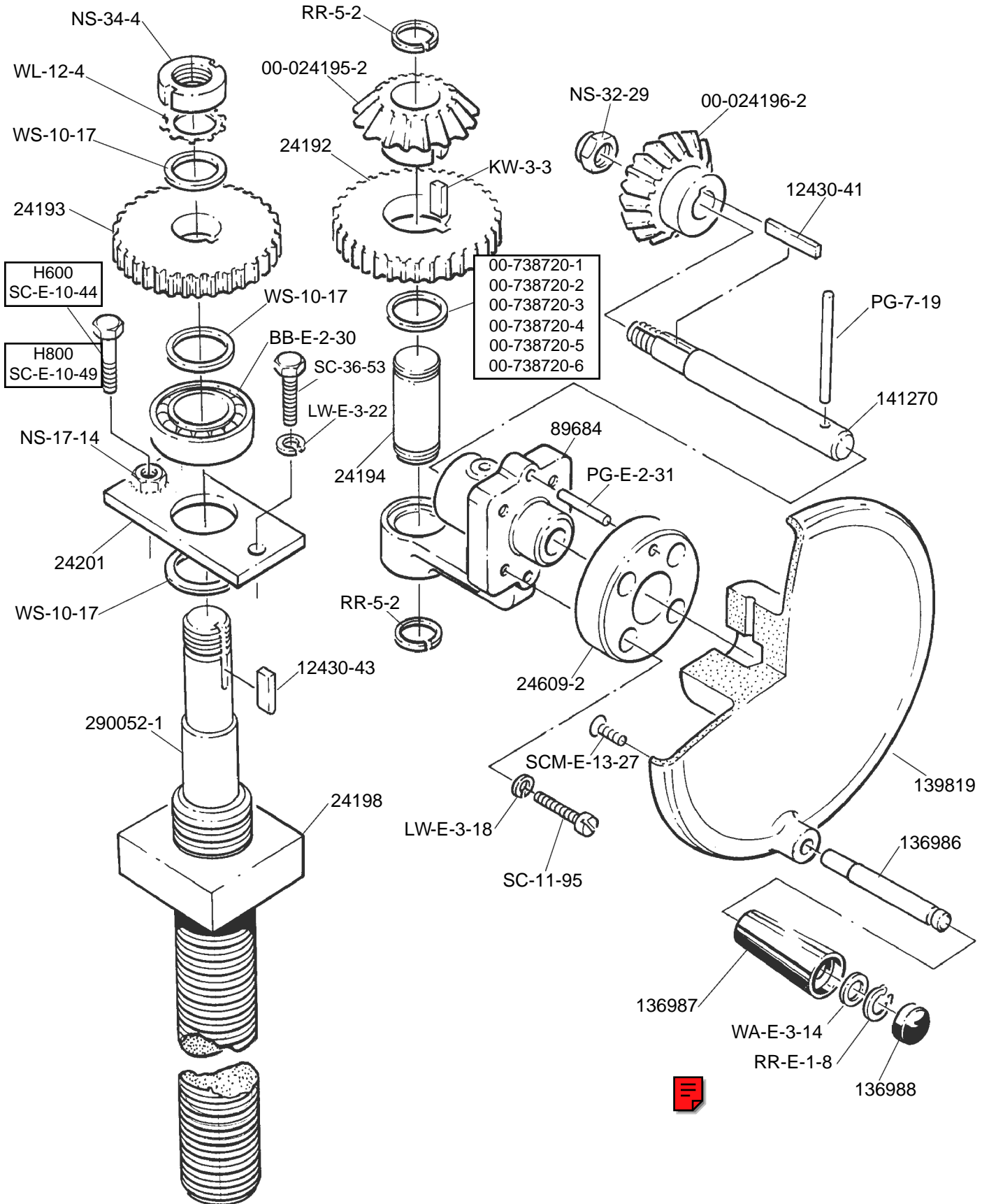

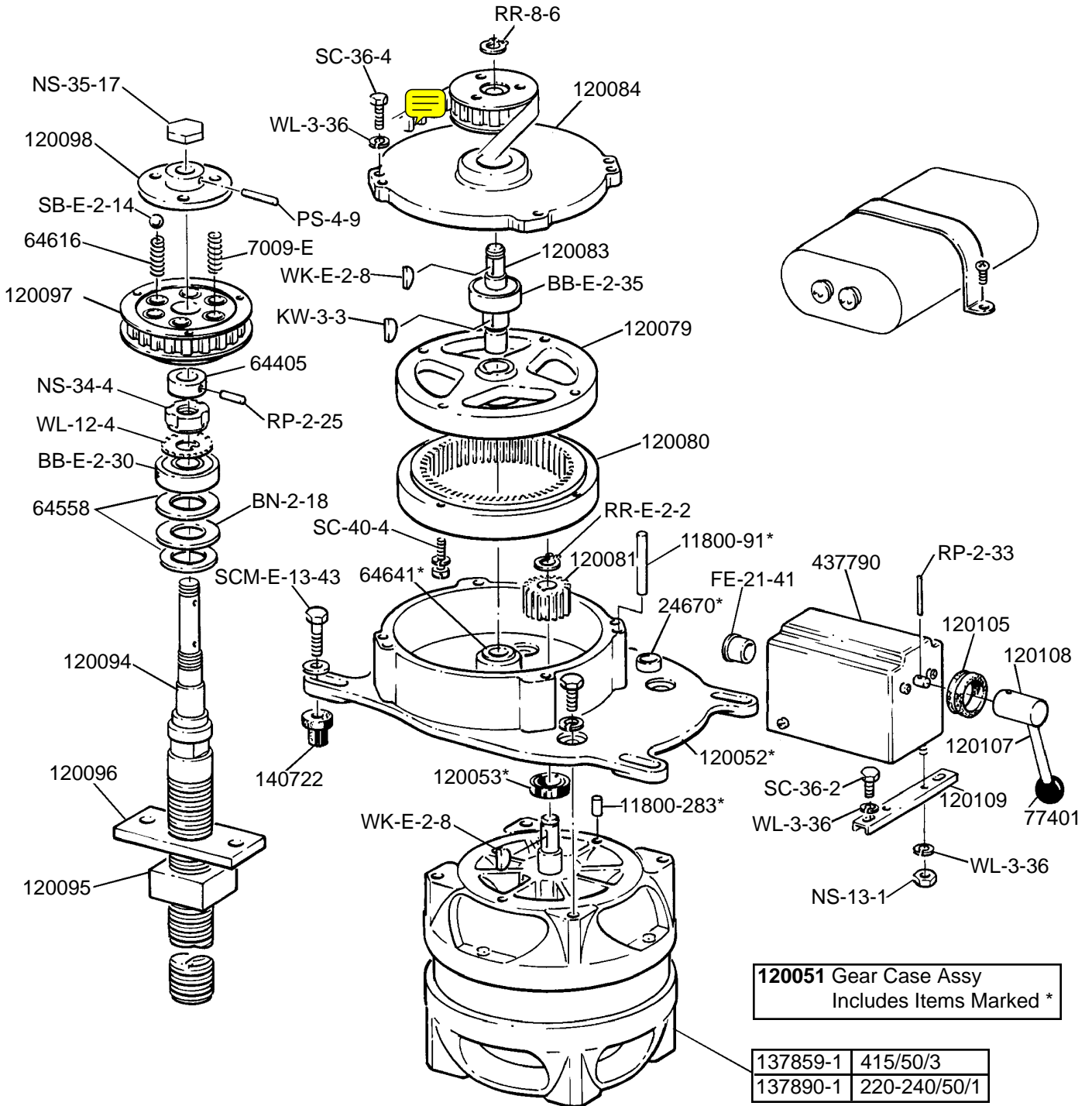

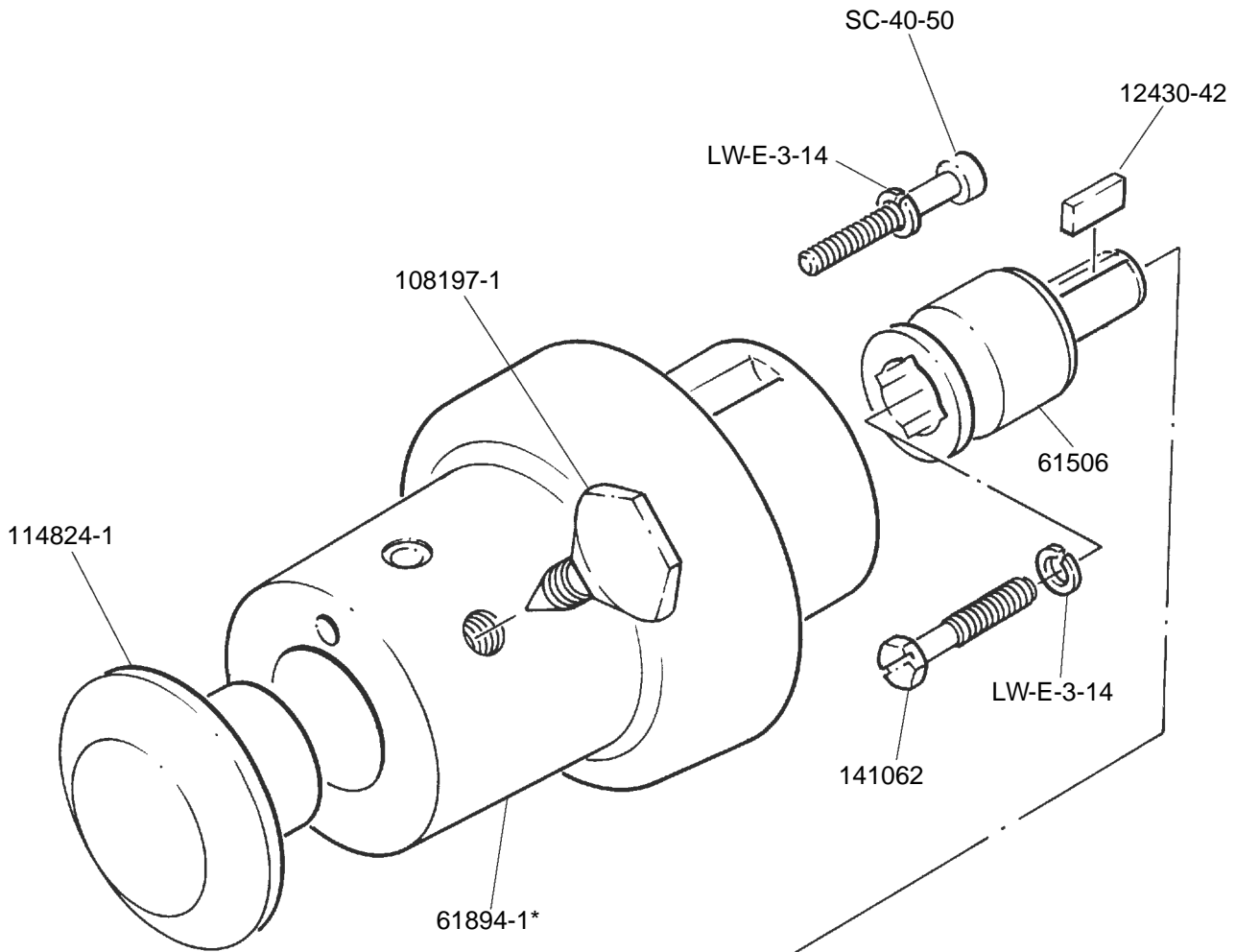

141818 Attachment Hub Sub-Assy
 Includes Items Marked *

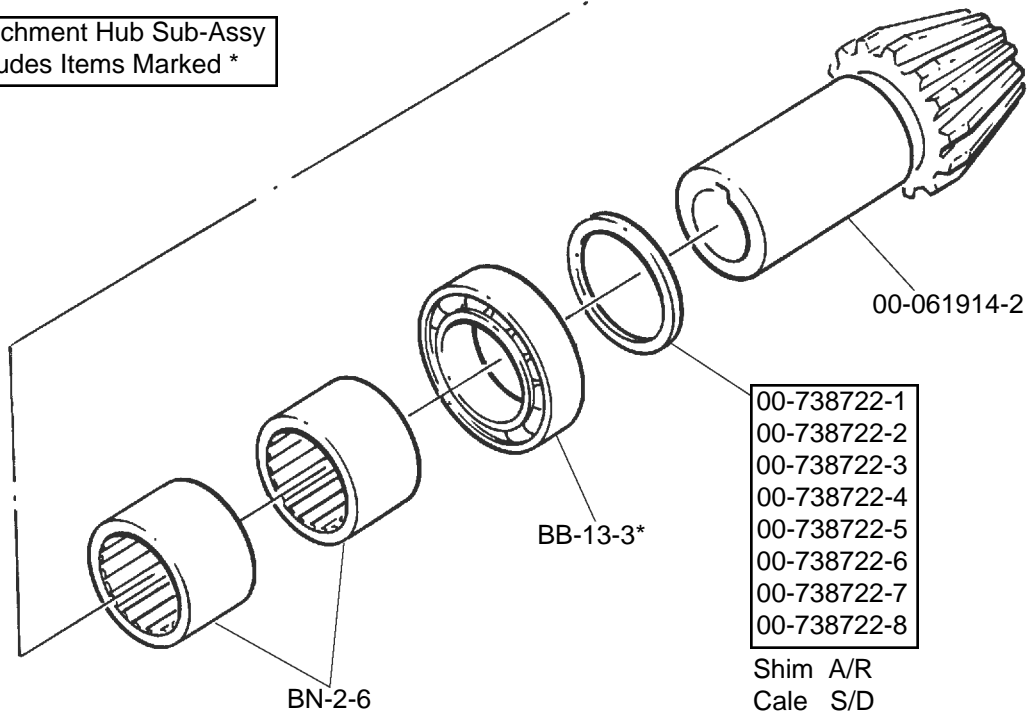

- 00-738722-1
- 00-738722-2
- 00-738722-3
- 00-738722-4
- 00-738722-5
- 00-738722-6
- 00-738722-7
- 00-738722-8

Shim A/R
 Cale S/D
 Abstandsscheibe NB

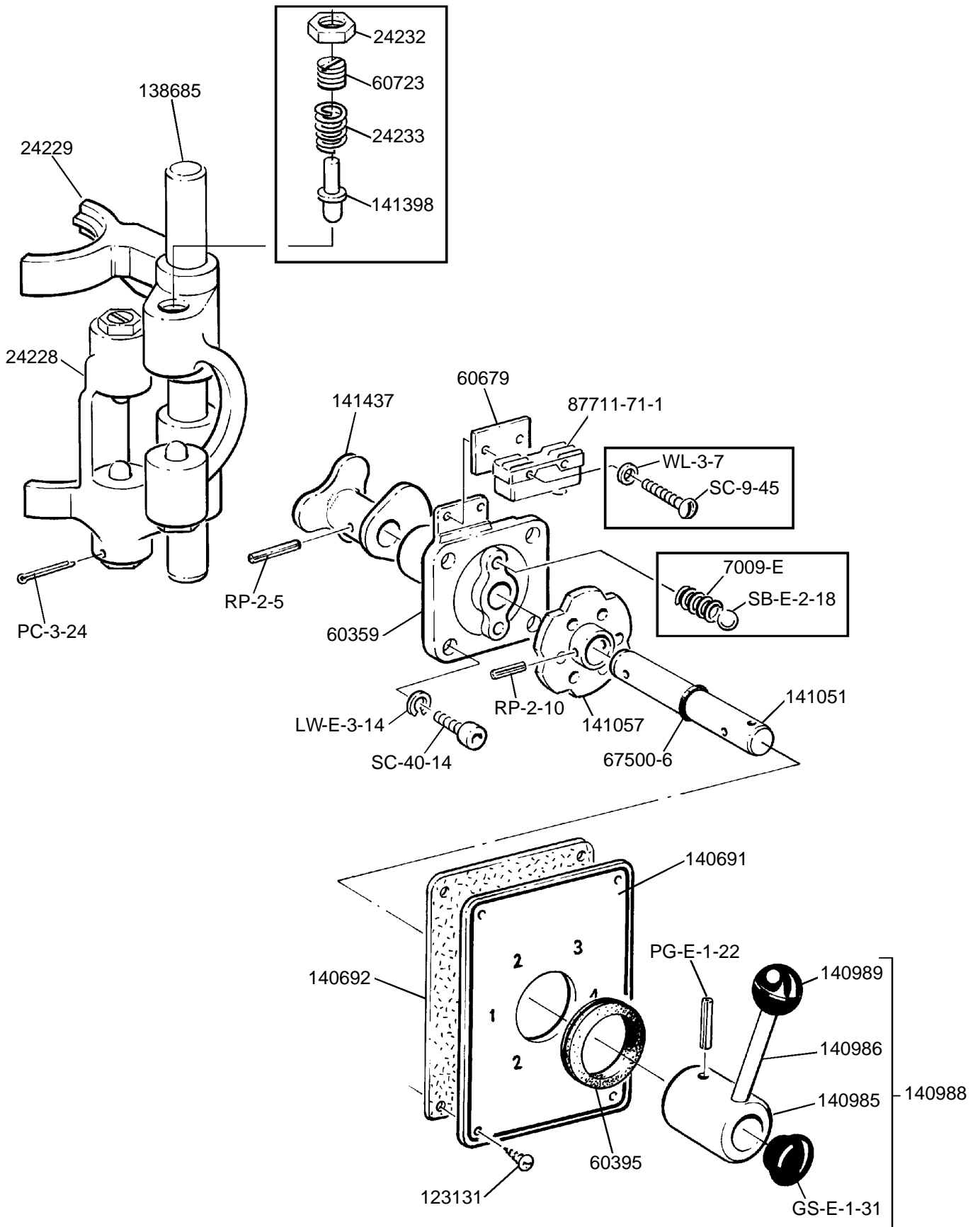

00-738717-4	.150"
00-738717-5	.150"
00-738717-6	.150"
00-738717-7	.150"
00-738717-8	.150"
00-738717-9	.150"
00-738717-10	.150"
00-738717-11	.150"
00-738717-12	.150"

Shims - A/R

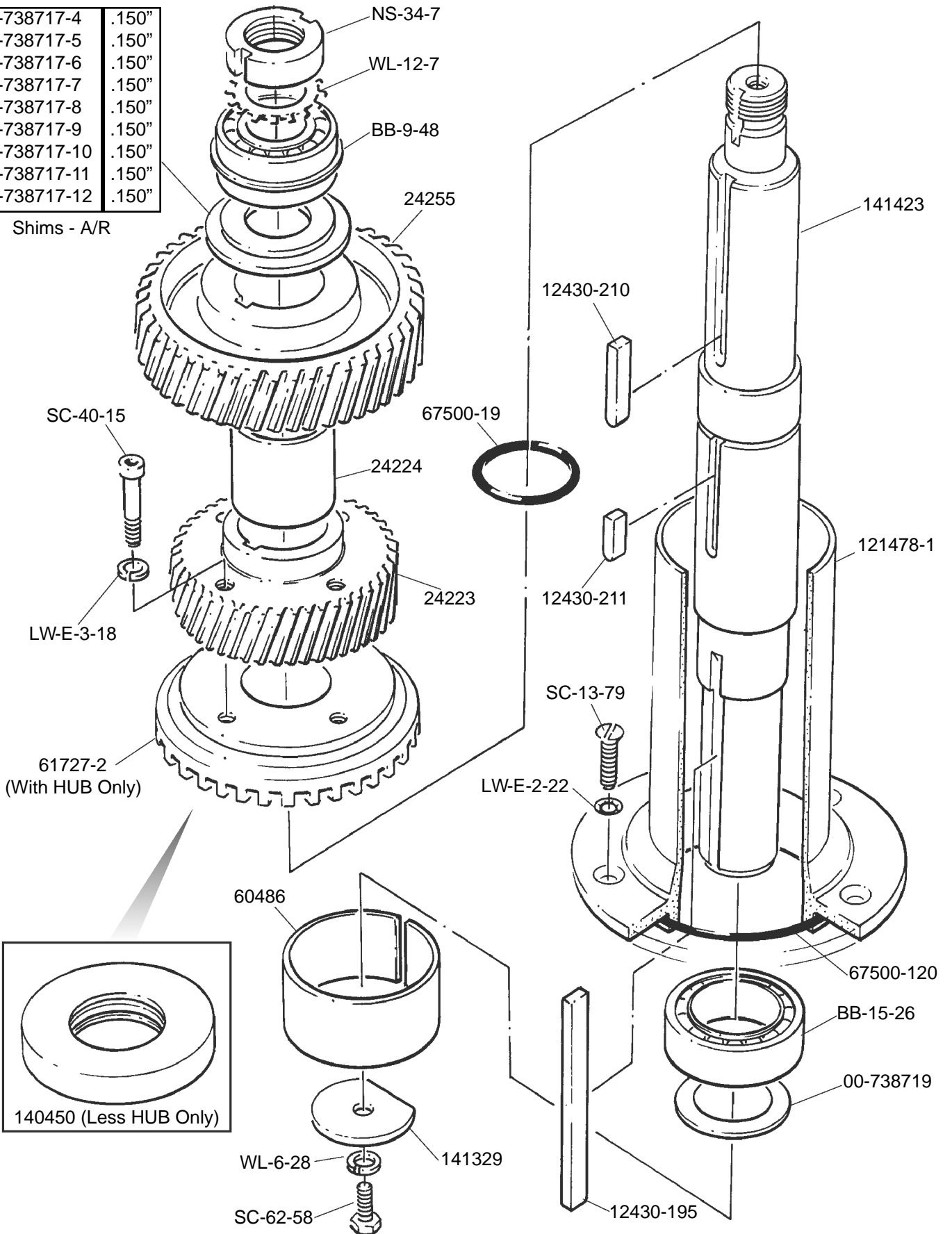

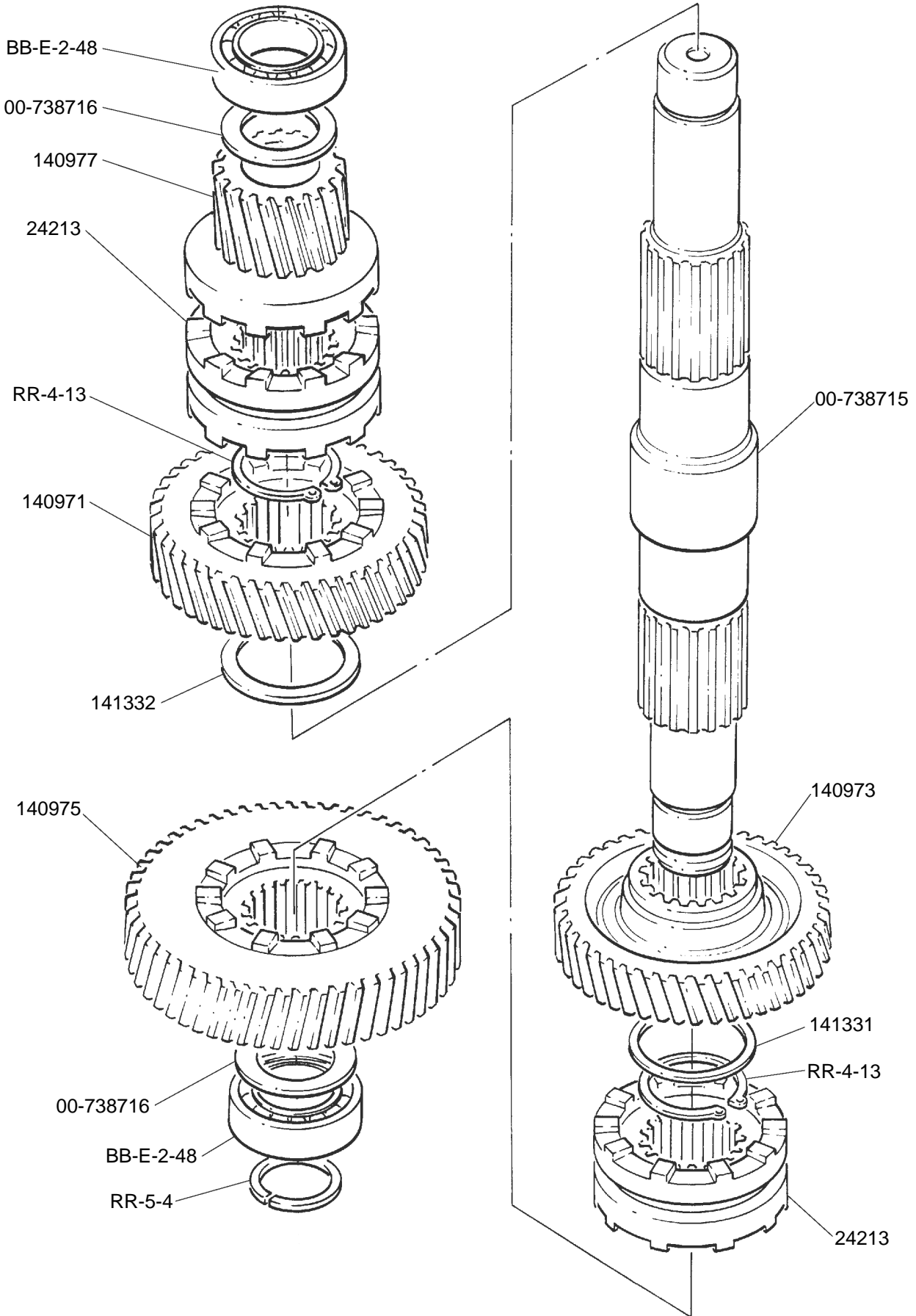

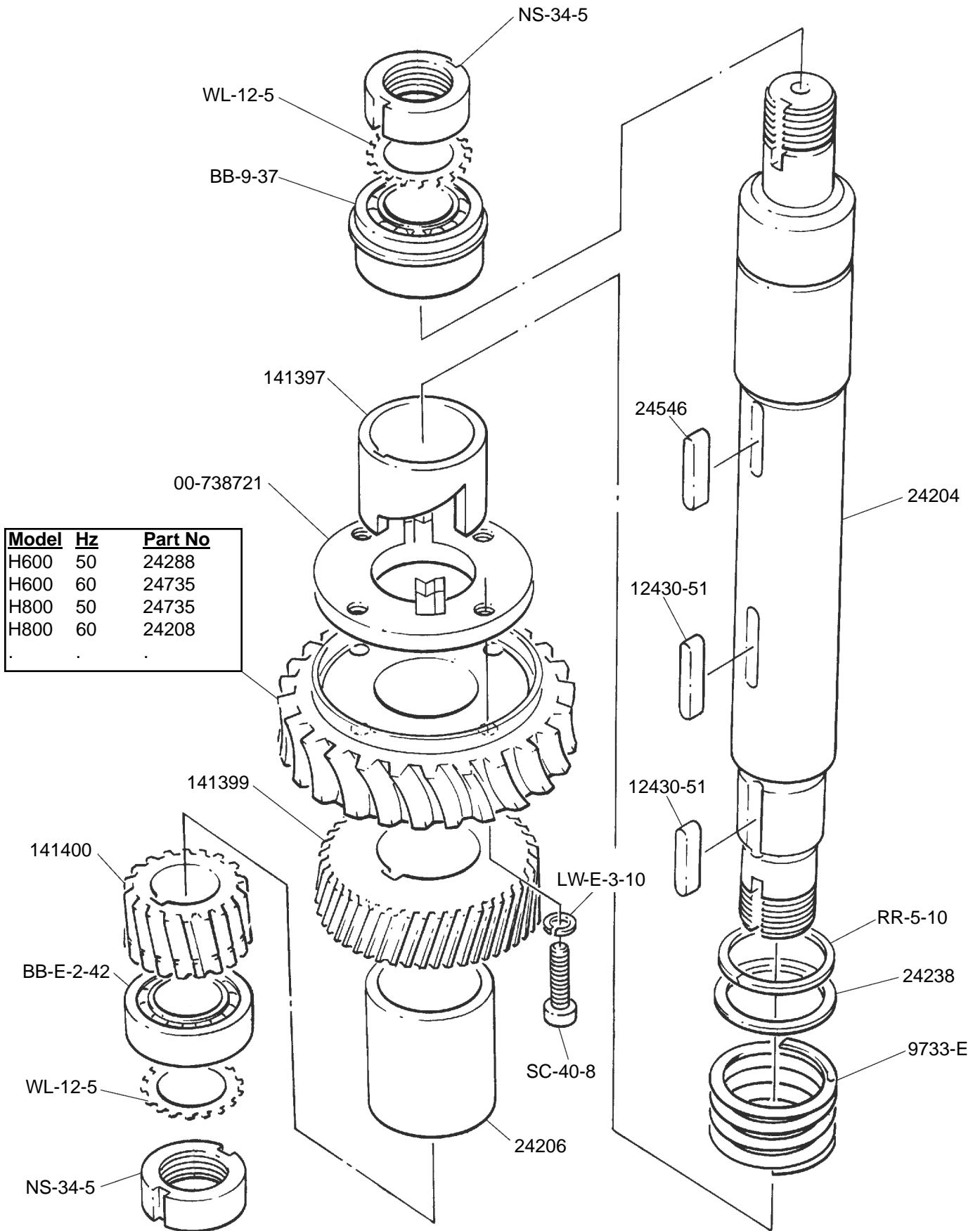

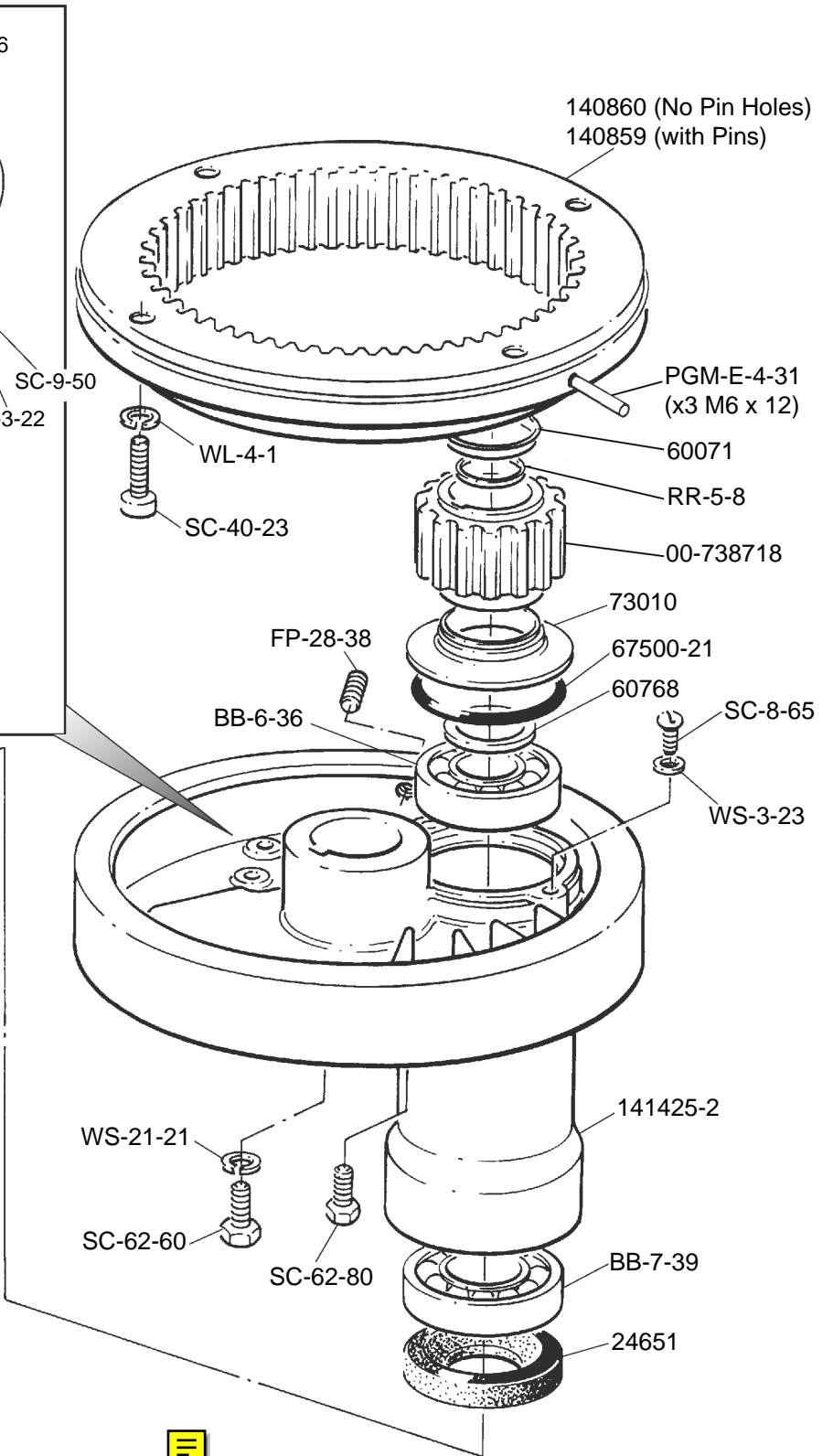
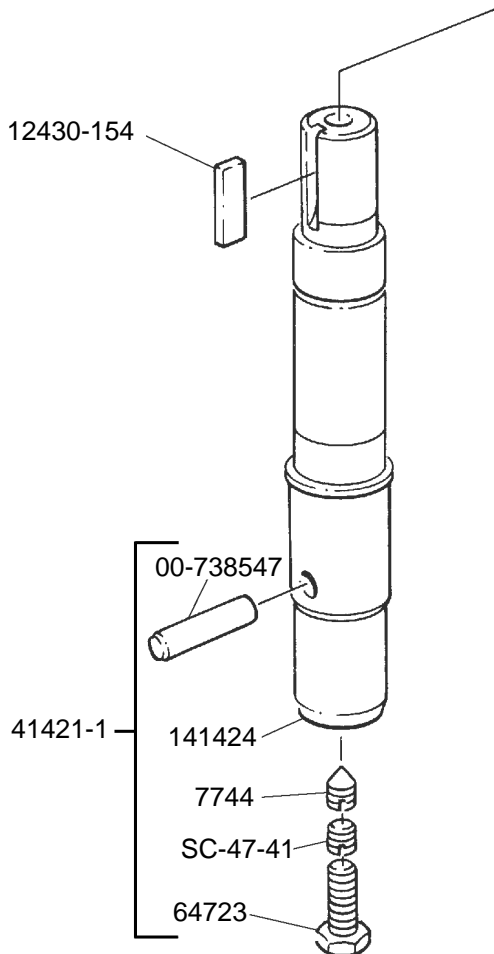
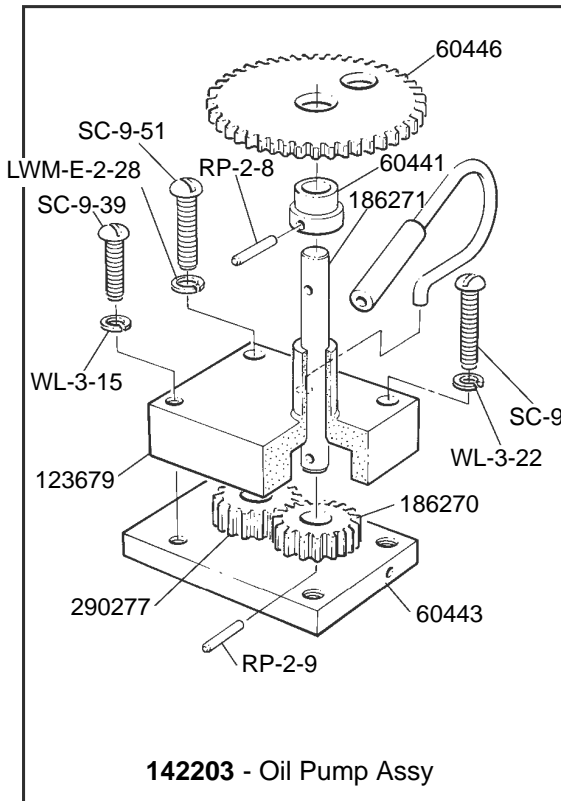

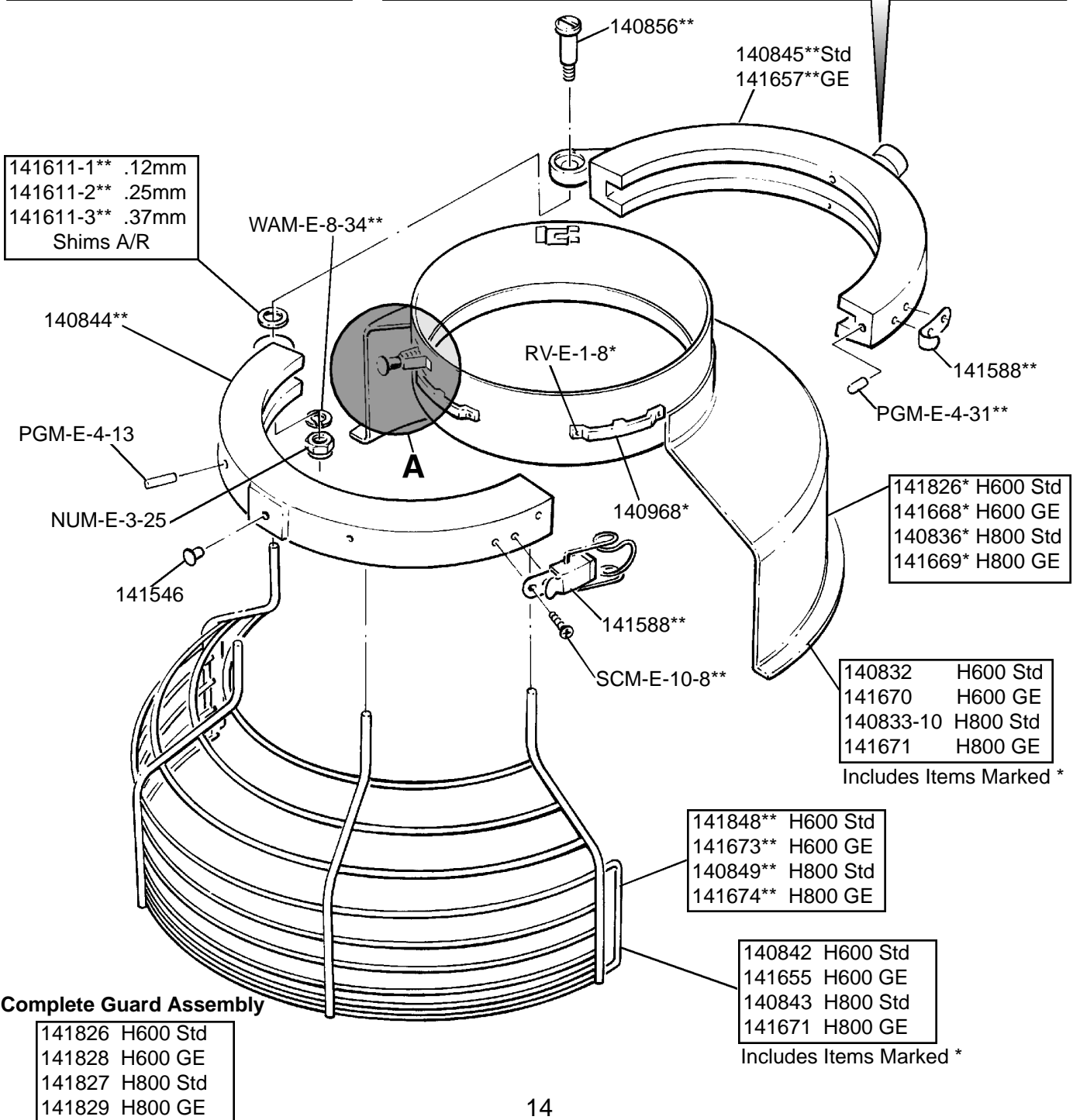
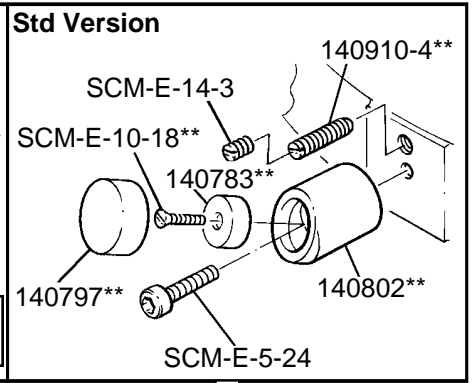
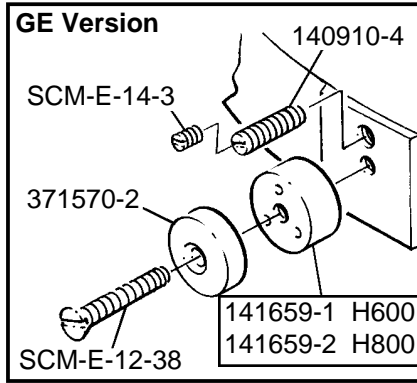
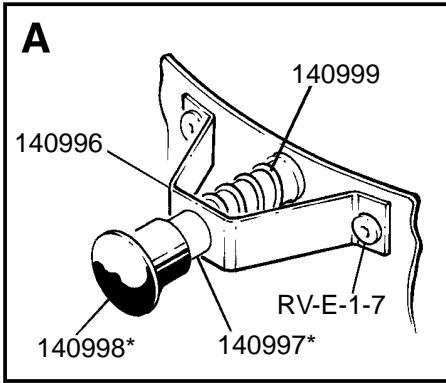

NOTE:-
Splash Guard Assy **00-437450**
(Includes Items Marked *)

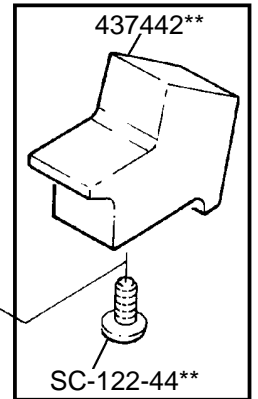
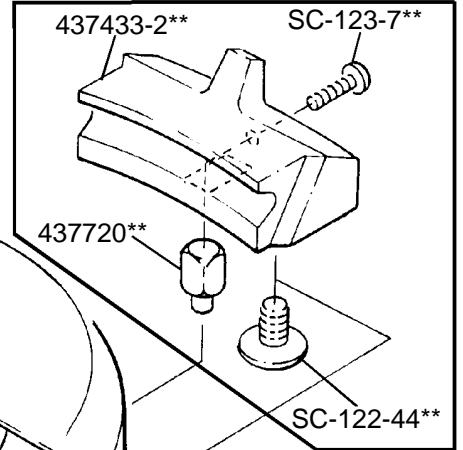
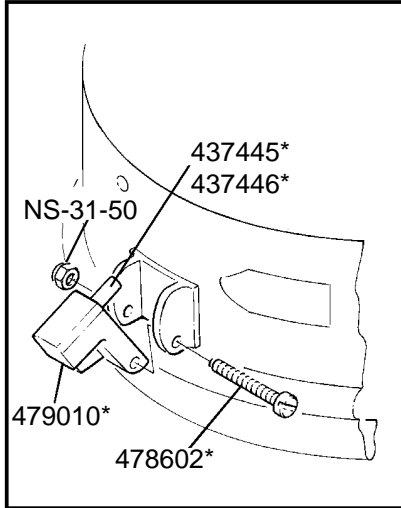

**PUSH HERE TO
TURE CAGE**
00-438712*

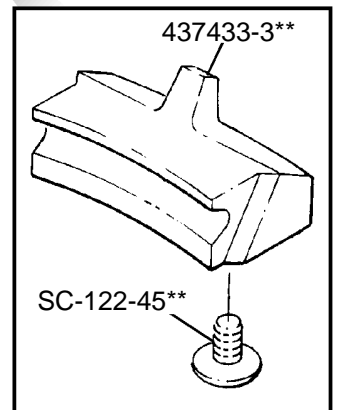
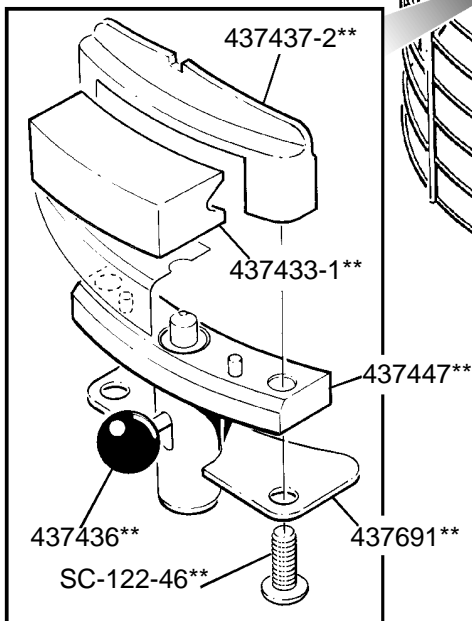
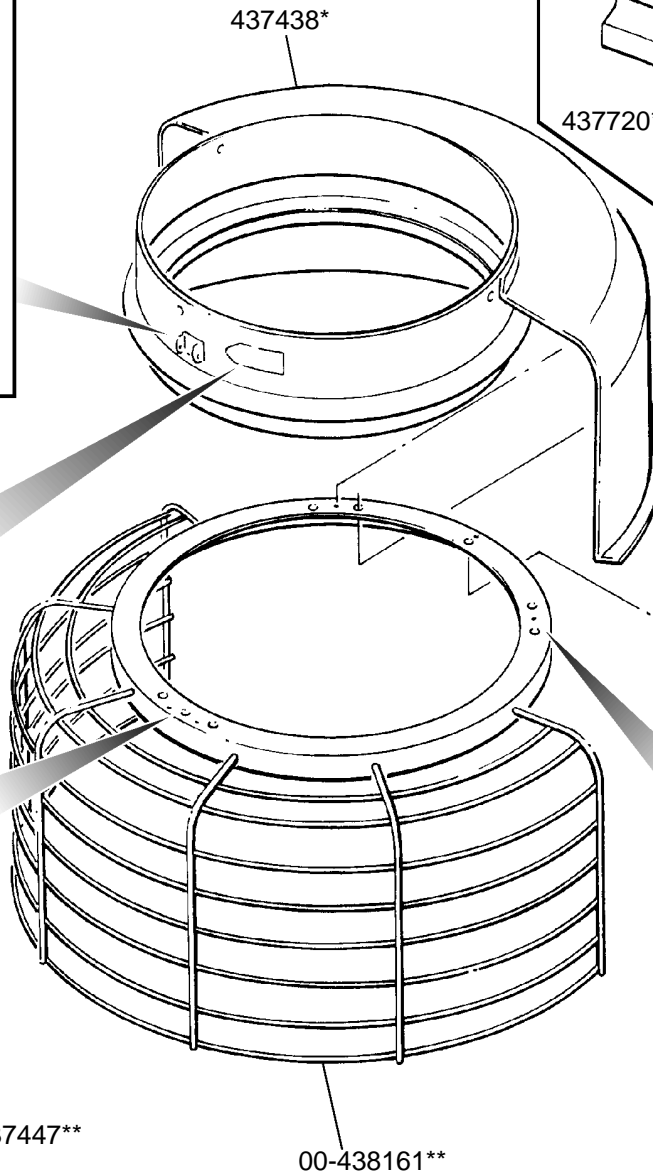

NOTE:-
Cage Assy = **00-438160**
(Includes Items Marked **)



230/50/1 Motor 137416-1 H600 141435-1 H800
400/50/3 Motor 00-738453-1 H600 & H800

291457-2 50Hz 291457-1 60Hz

67500-24

RP-2-4

PG-E-2-31



24291 50Hz H600 24298 60Hz H600 24298 50Hz H800 24208 60Hz H800
--

24610

SC-36-98

WL-3-43

LW-E-3-25

SC-36-28

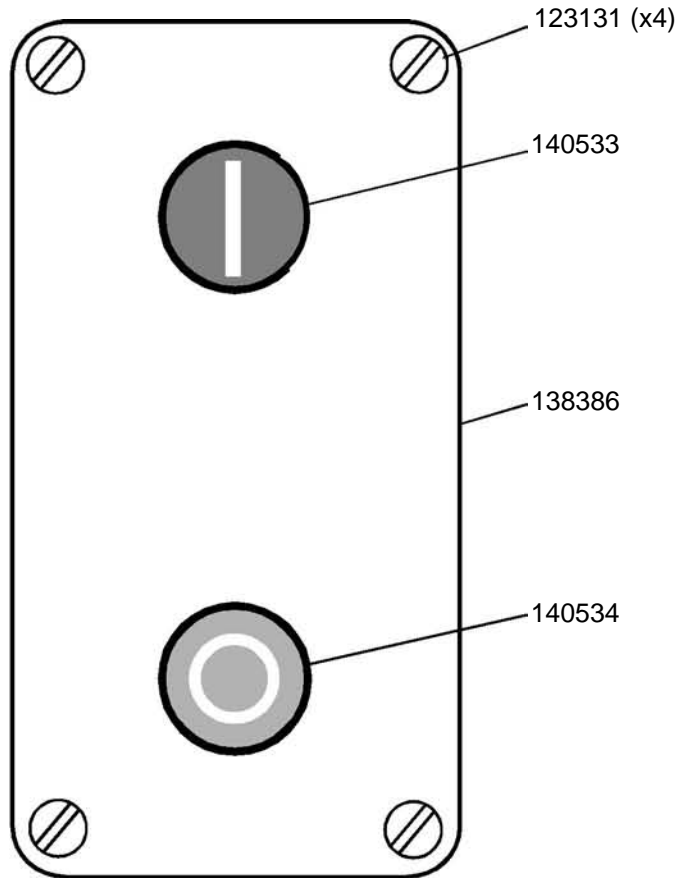

**Timer / minuterie
Zeitschater**
15min SS-E-18-10
30min SS-E-18-11

**Plate Timer / Plaque minuterie
Zeitschaterplatte**
15min 139396
30min 139869

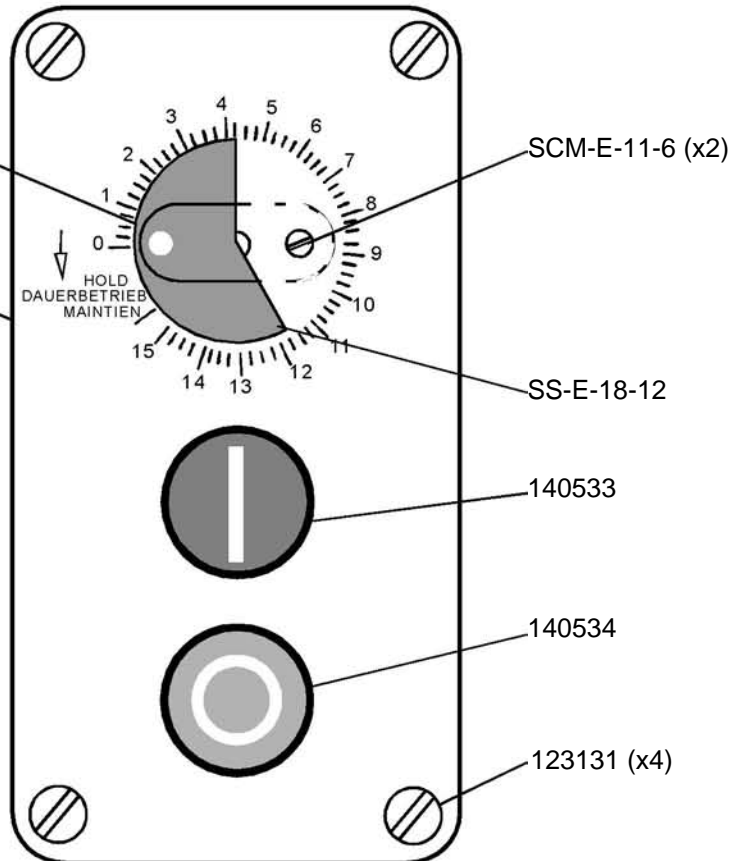

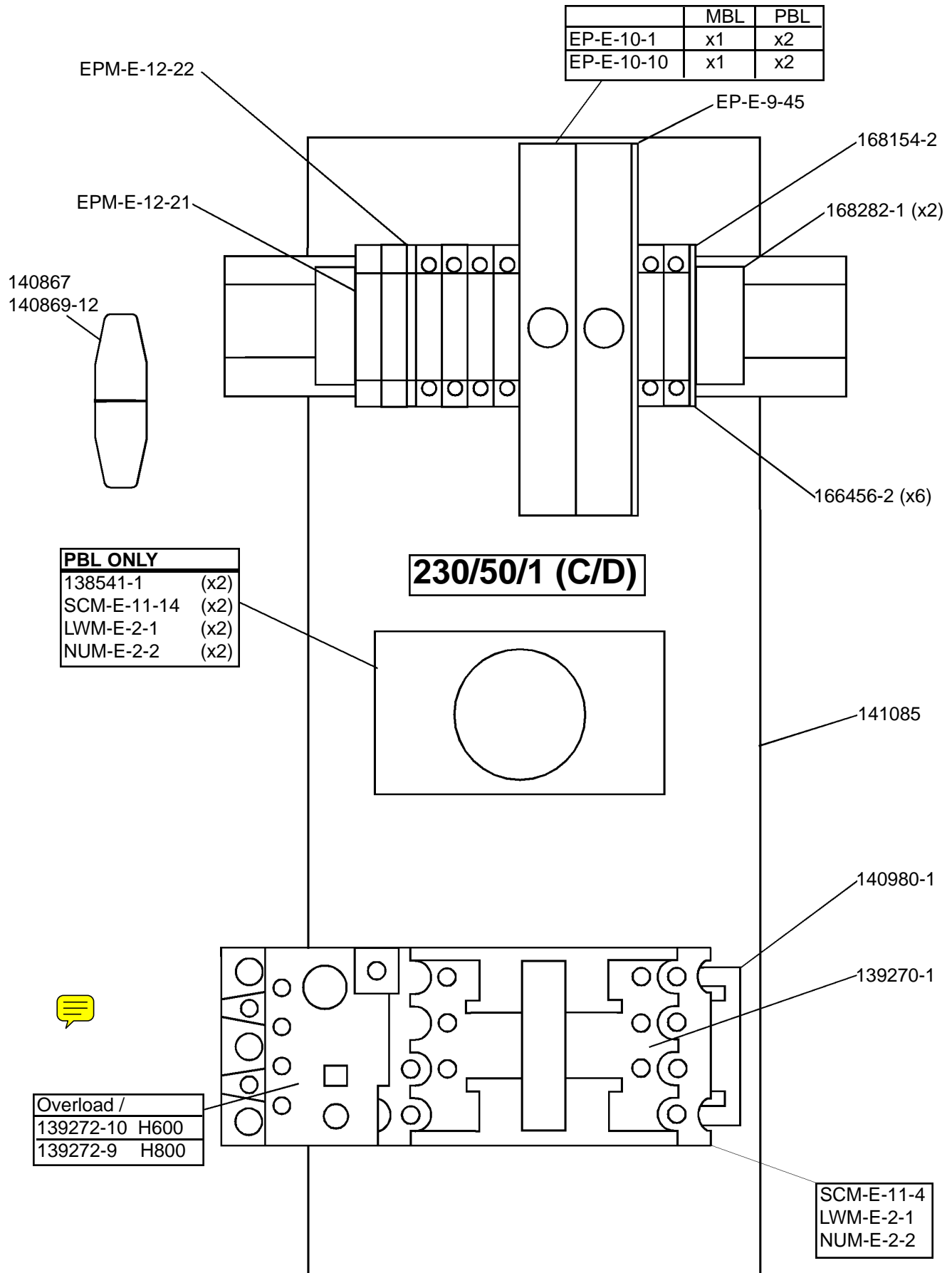

230/50/3 (F/G)
400/50/3 (H/S)
400/50/3+ (K/L)

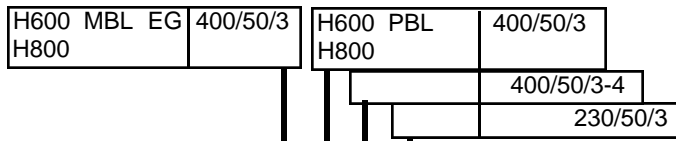

SCM-E-4-37
LWM-E-2-35
NUM-E-2-27

EP-E-10-1	x3	x6	x1	x2
EP-E-10-10	x3	x6	x1	x2

EP-E-9-45

166456-2 (x7) 400/50/3
(x8) 400/50/3-4

168154-2
Germany Only
371568-1
142031 168282 (x2) (x2)
SCM-E-11-30 (x2)
NUM-E-2-22 (x2)

140867
140869-12

57136-1
SCM-E-3-8 (x2)
LWM-E-2-1 (x2)
NUM-E-2-22 (x2)
400/50/3 Only

OVERLOAD/

139272-8	H600	400/50/3
139272-9	H800	400/50/3-4
	H600	230/50/3
	H800	230/50/3
	H600	400/50/3-4
	H800	400/50/3-4

PBL ONLY
141440-11 (x2)
144251 - 144252
SCM-E-11-14 (x6)
LWM-E-2-1 (x6)
NUM-E-2-22 (x6)

140980-1

139270-1

SCM-E-11-14 (x2)
LWM-E-2-1 (x2)
NUM-E-2-2 (x2)

141085

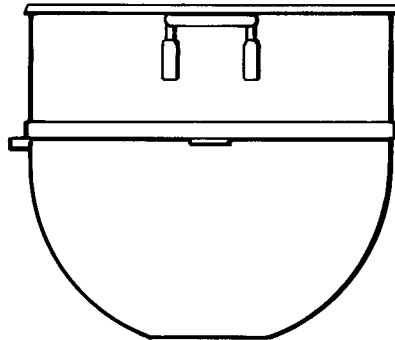

295648	H600	30qt S/S Bowl
275686	H600 / H800	40qt S/S Bowl
66462	H600	60qt S/S Bowl
59780	H800	80qt S/S Bowl

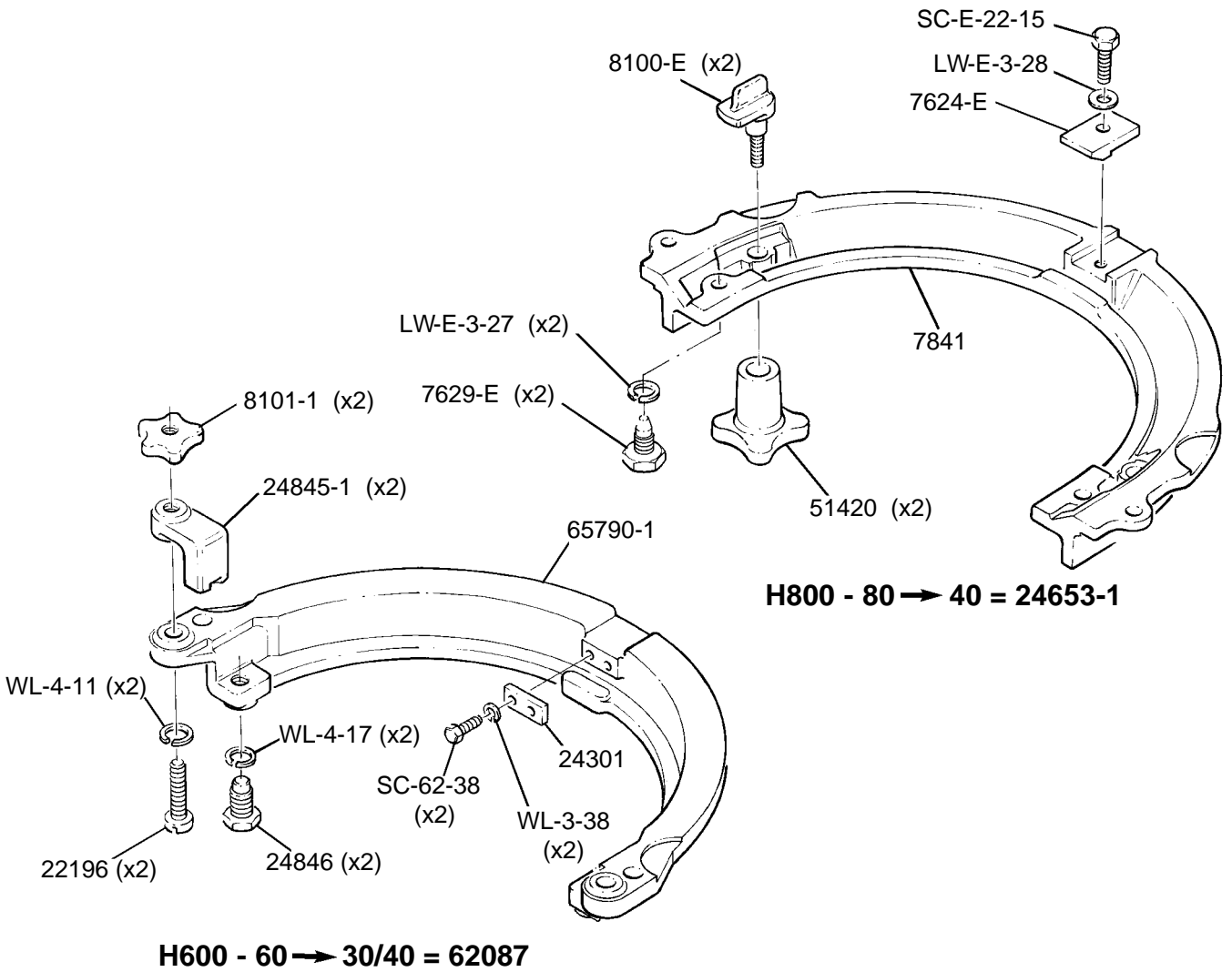

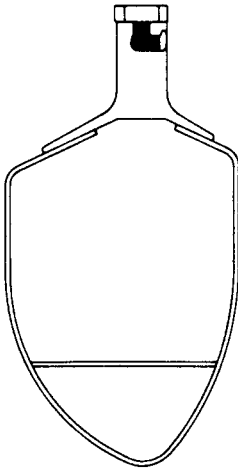

	H600	H800
30qt	275159	-
60qt	68096	-
80qt	-	52396

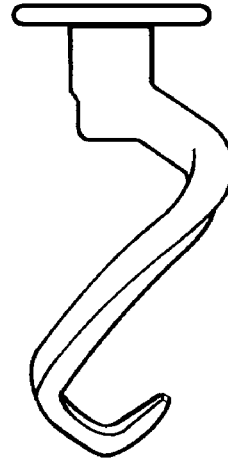

	H600	H800
40qt EB	295176	
60qt ED	141430	-
40qt M	-	8151-E
80qt ED	-	141431

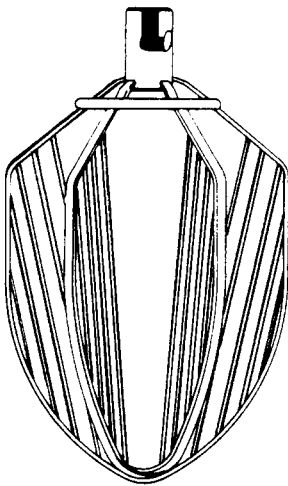

	H600	H800
40qt	295159	-
60qt	295156	-
80qt	-	53339

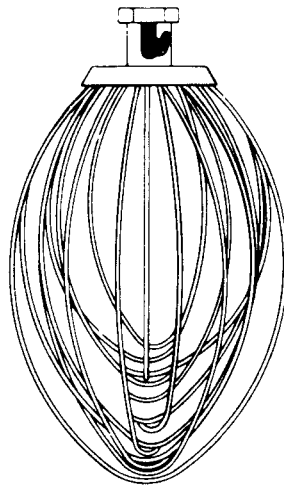

	H600	H800
30qt	439740	-
40qt	9006-E	9006-E
60qt	-	-
80qt	-	52912

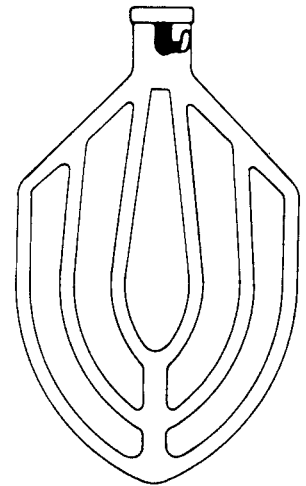

	H600	H800
30qt	275809	-
40qt	12108-E	12108-E
40qt s/s	55662	8151-E
60qt	141429-1	-
60qt s/s	275886	-
80qt	-	52312
80qt s/s	-	53309

SERVICE

Hobart trained service technicians strategically located at the listed Hobart branches are prepared to give you fast, efficient and reliable service. Protect your investment by having a Hobart inspection contract, which assures the continued, efficient operation of your Hobart machines, spares and accessories.

For further details contact:-

SALES: 07002 101 101
SERVICE: 07002 202 202
SPARES: 07002 303 303

Continued product improvement is a Hobart Still policy, specifications may change without notice.

Hobart ayant une politique d'amélioration constante de ses produits, les spécifications peuvent changer sans préavis.

Unsere Produkte werden ständig verbessert. Deshalb behält sich Hobart Still Änderungen der technischen Daten ohne Vorankündigung vor.

Hobart UK
Hobart House, 51 The Bourne,
Southgate, London N14 6RT
Tel: 020 8920 2800 Fax 020 8886 0450
www.hobartmfg.co.uk

HOBART

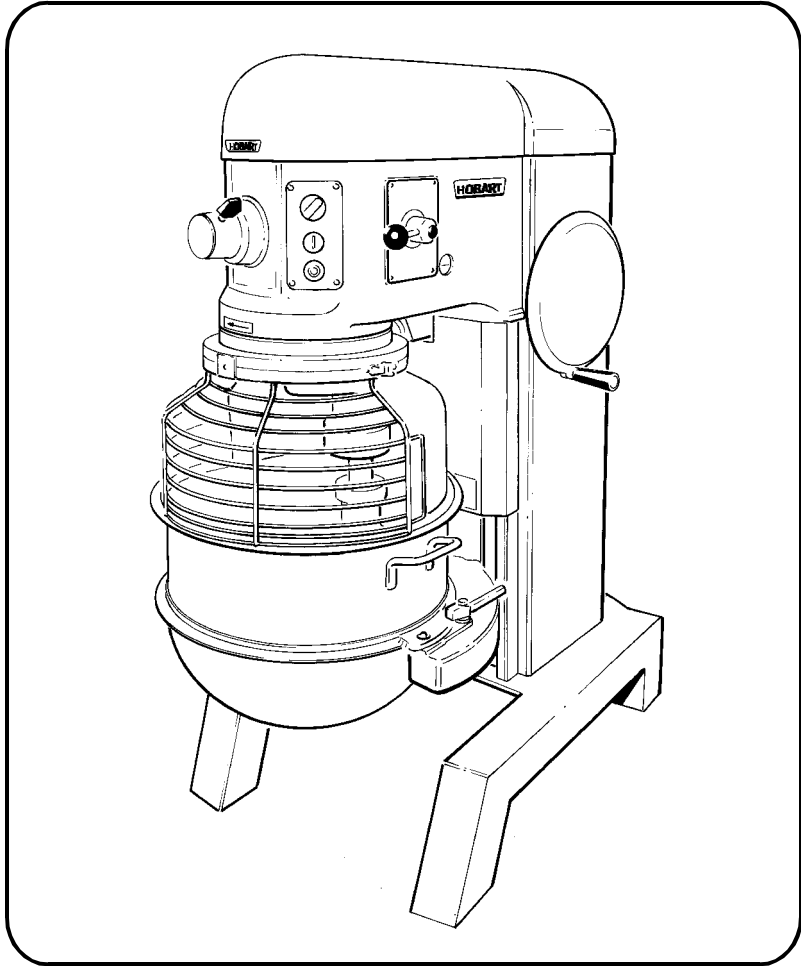

H600 / H800

**Catalogue of Replacement Parts
Catalogue de Pieces de Rechange
Ersatzteilkatalog**

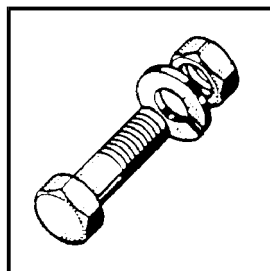
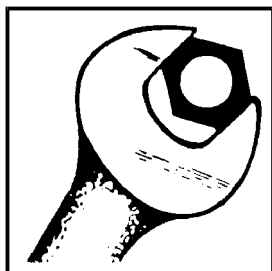

Page Seite	
2	Base and pedestal unit Base et Colonne Gehäuse mit standfüßen
3	Transmission case unit Boîte de vitesses Antriebsgehäuse
4/5	Bowl support and bowl lift Support et relevage de bol Kesselheber und haalterung
6	Power Bowl Lift Relevage Automatique de bol Automatischer Kesselhub
7	Attachment hub Cannon port-accessoires Ansatznabe
8	Shifting Unit Changement de vitesses Geschwindig Keitswahlschalter
9	Planetary Shaft Planétaire arbe Planetengetriebewelle
10	Clutch Shaft Arbe des clabots Kupplungswelle
11	Worm Gear Shaft Arbe roue helicoidale Schneckenradwelle
12	Planetary Planetaire Planetengetriebe
13/16	Guard Assembly Sécurité de bol Schutzgitter
17	Motor Moteur Motor
18	Timer Minuterie Zeitschater
19/20	Electrics Électriques Elektrik
21	Bowls and Equipment Bols et Équipement Kessel und Ausrüstung
22	Agitators Agitateurs Rührwerkzeuge

NOTE:

The paint colour scheme for the H600 / H800 mixers has changed.
This change was effective from serial number's 970162424 (H600) & 970161919 (H800)
For required items with the new colour scheme use the Part numbers with a - 9 suffix



Base and pedestal unit
Base et Colonne
Gehäuse mit standfüßen

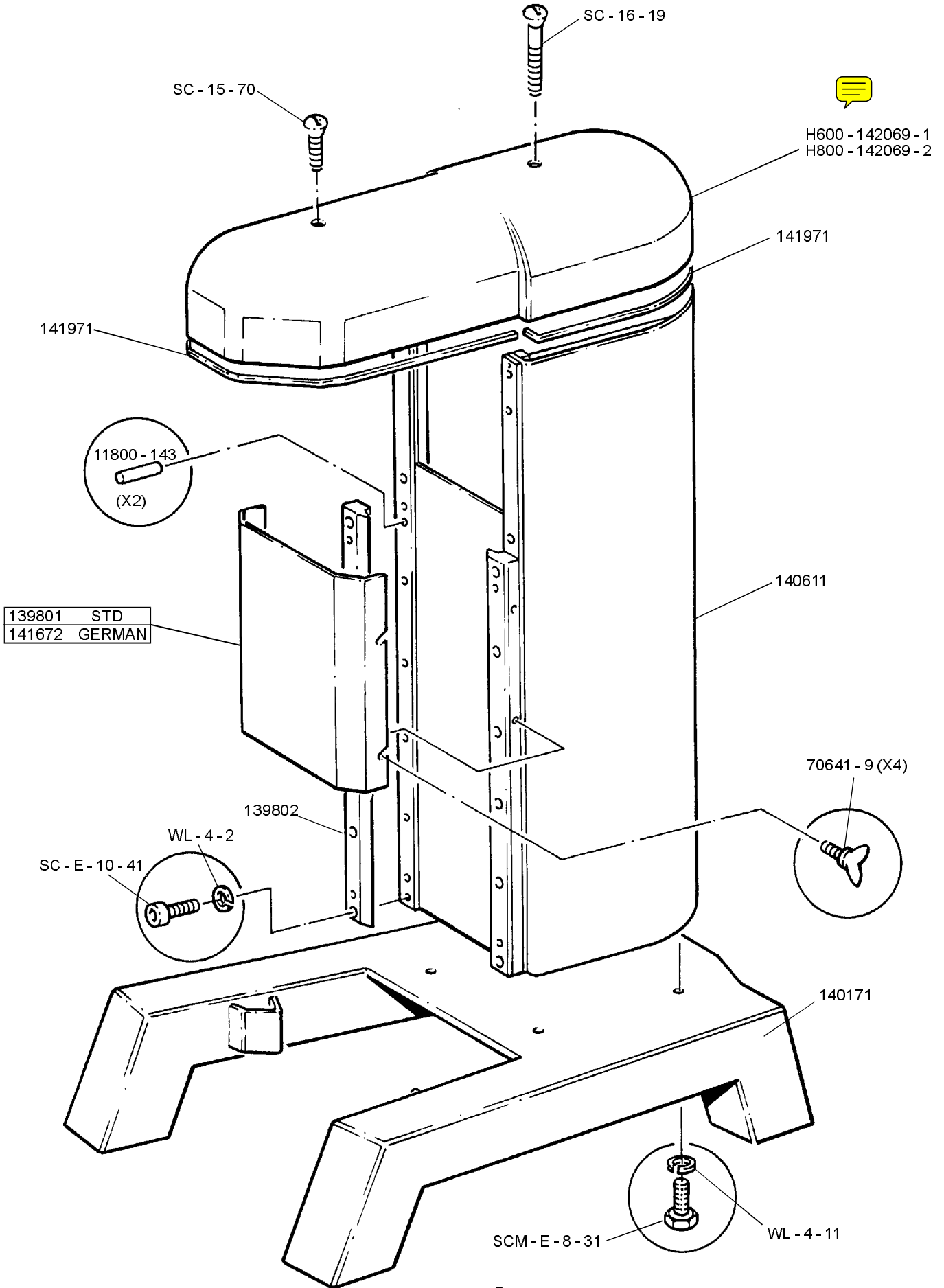

Transmission case unit
Boîte de vitesses
Antriebsgehäuse

H600
H800

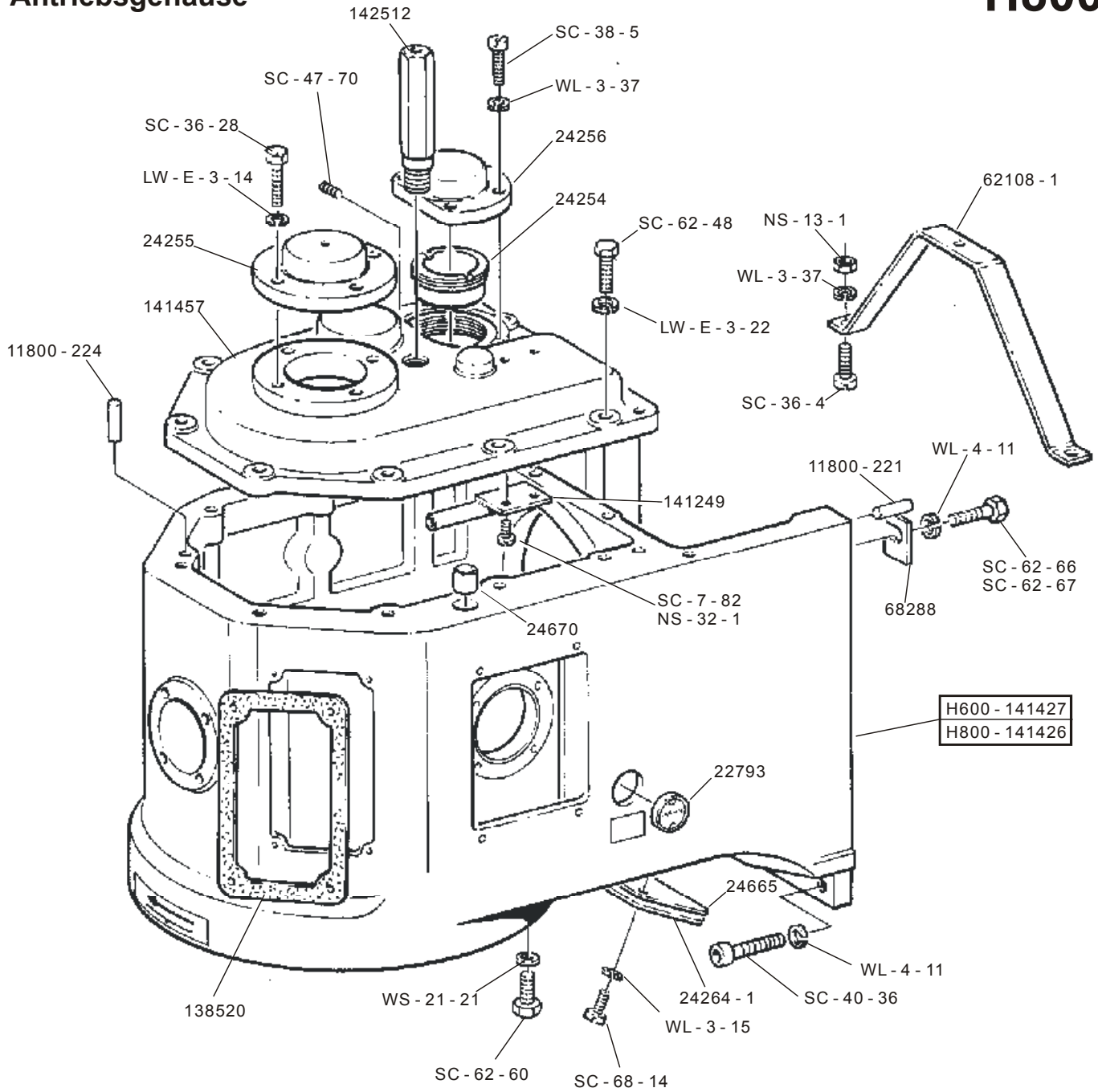



Bowl support and bowl lift
Support et relevage de bol
Kesselheber und haalterung

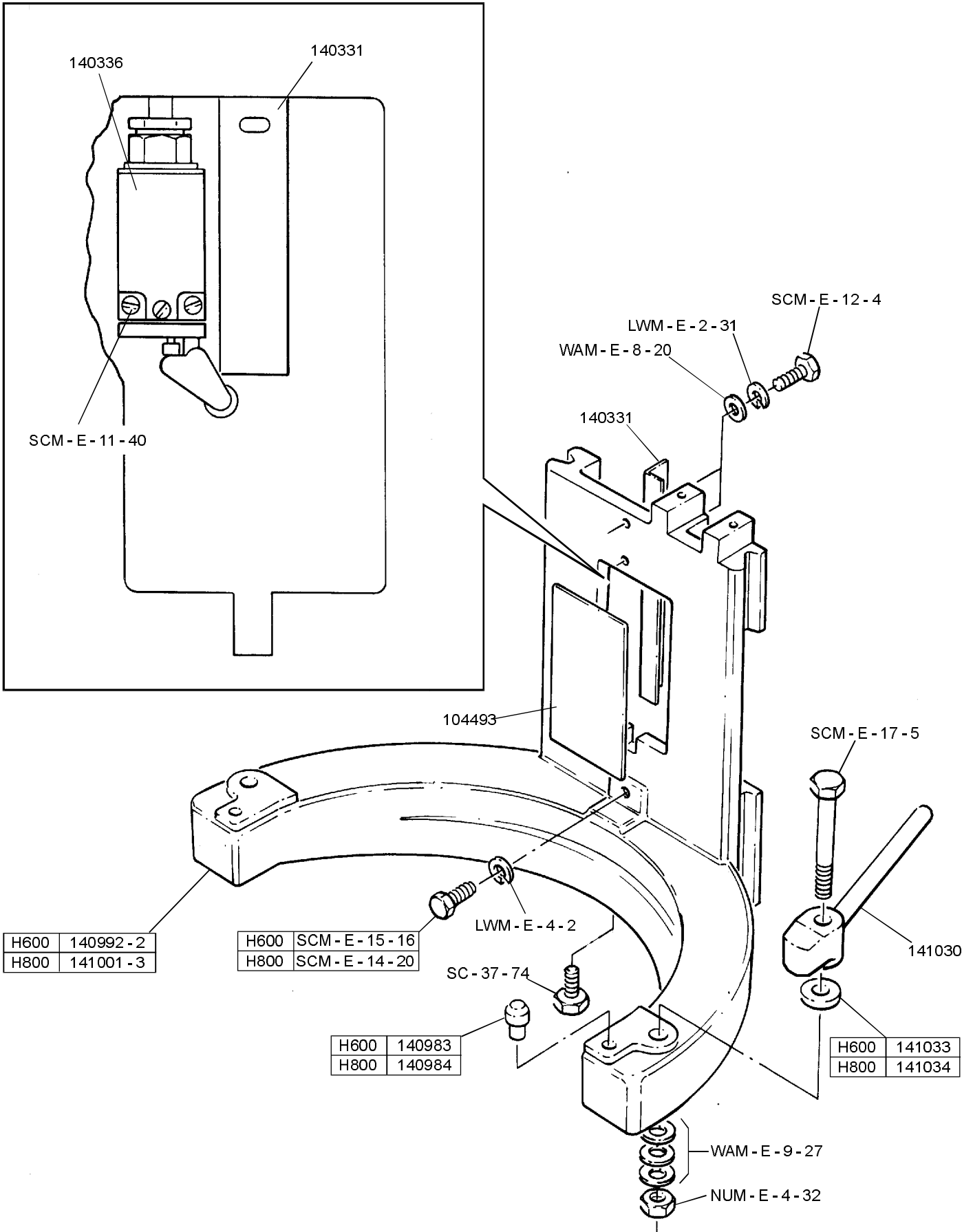

Bowl support and bowl lift
Support et relevage de bol
Kesselheber und haalterung

H600
H800

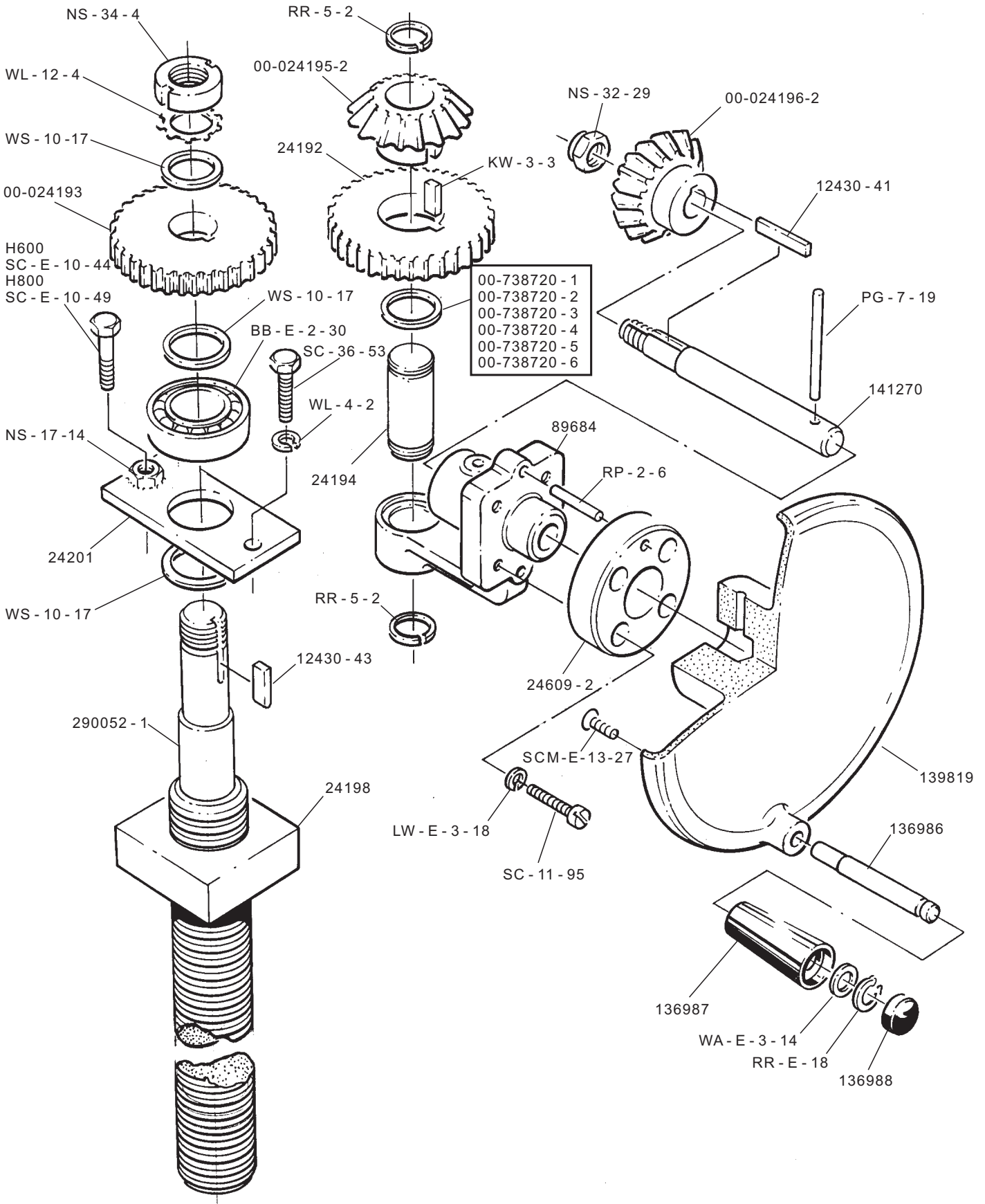



Shifting Unit
Changement de vitesses
Geschwindigkeitswahlschalter

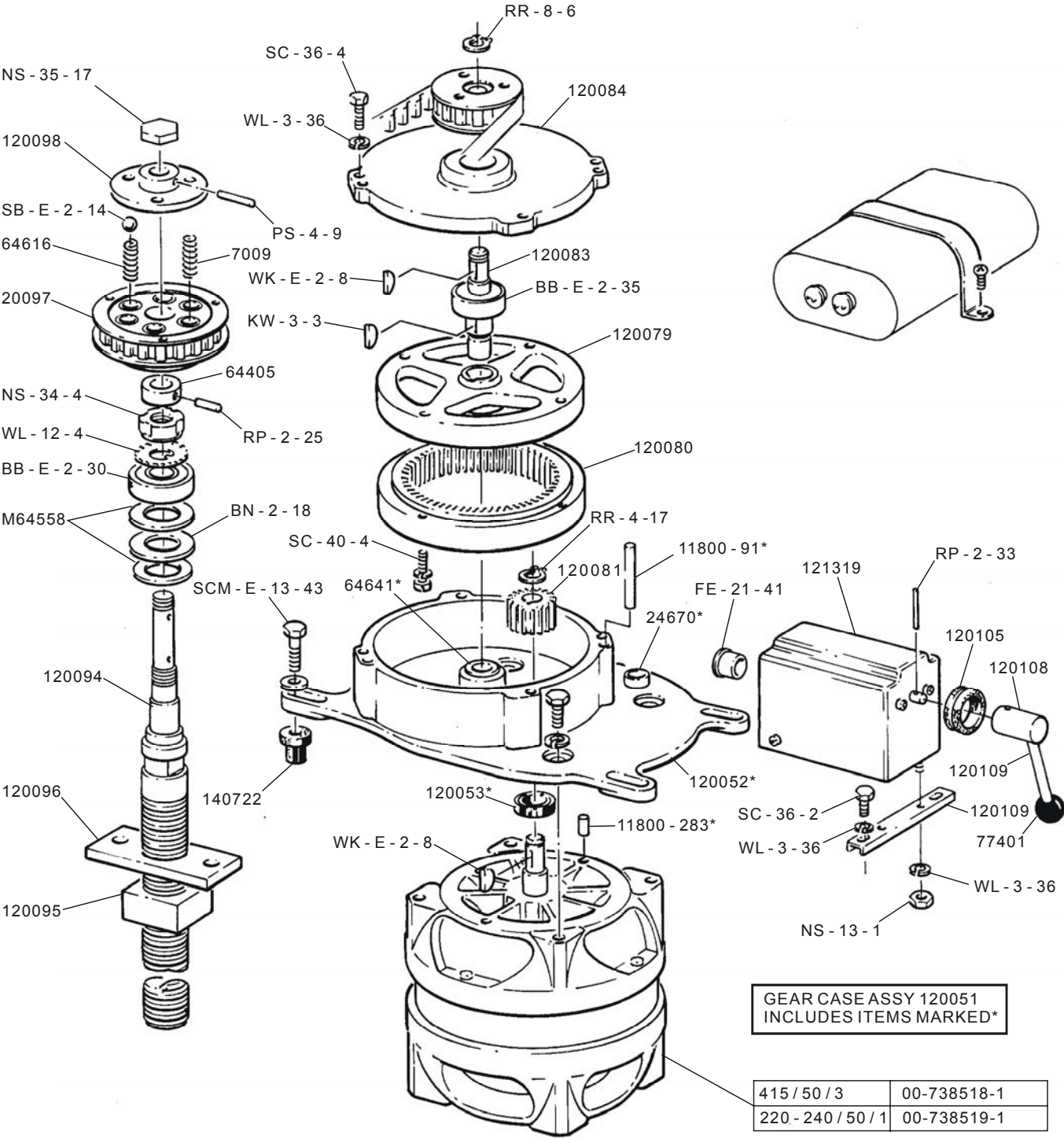

**Attachment hub
 Cannon port-accessoires
 Ansatznabe**

**H600
 H800**

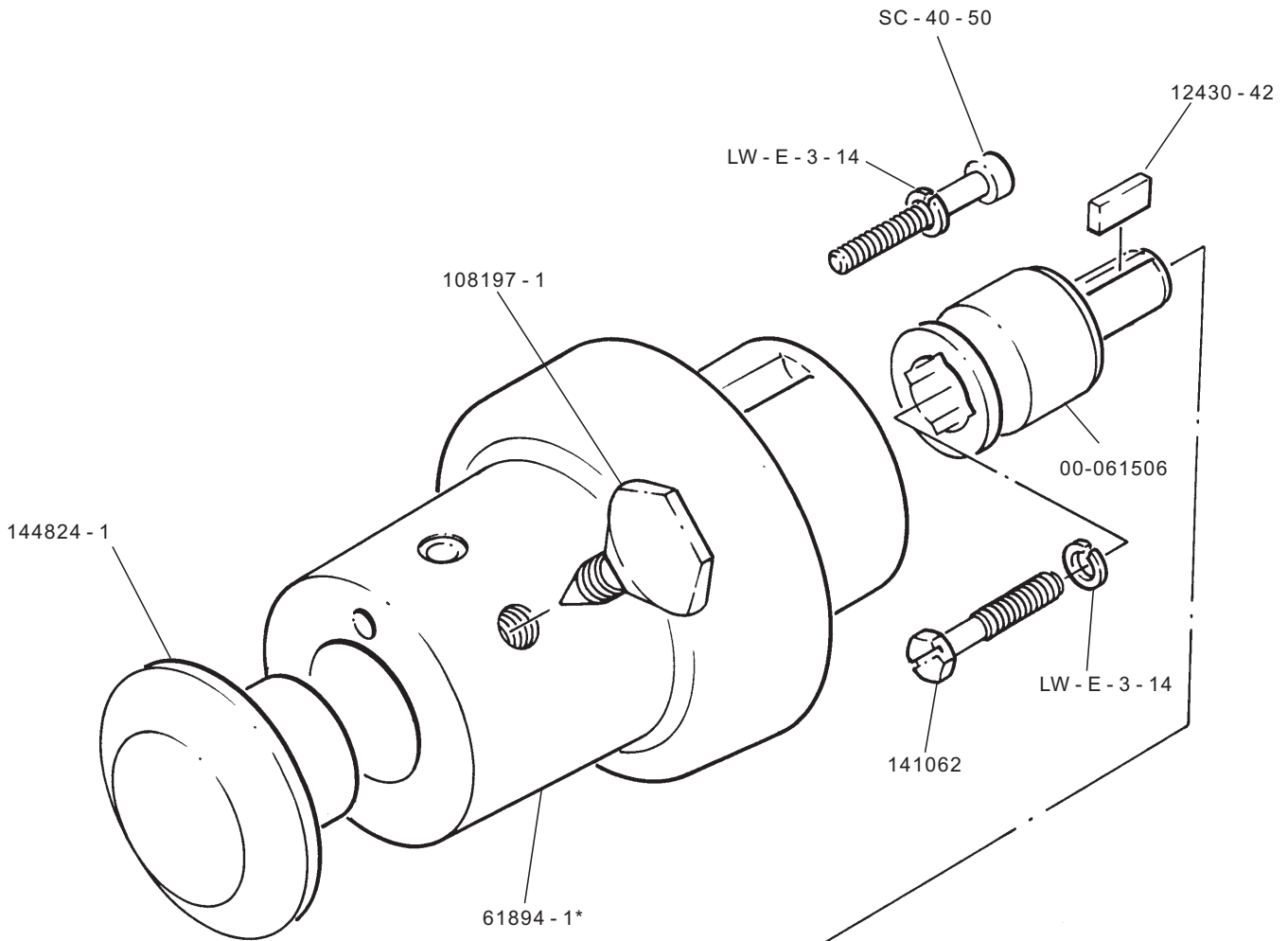

ATTACHMENT HUB SUB-ASSY 141818
 INCLUDES ITEMS MARKED *

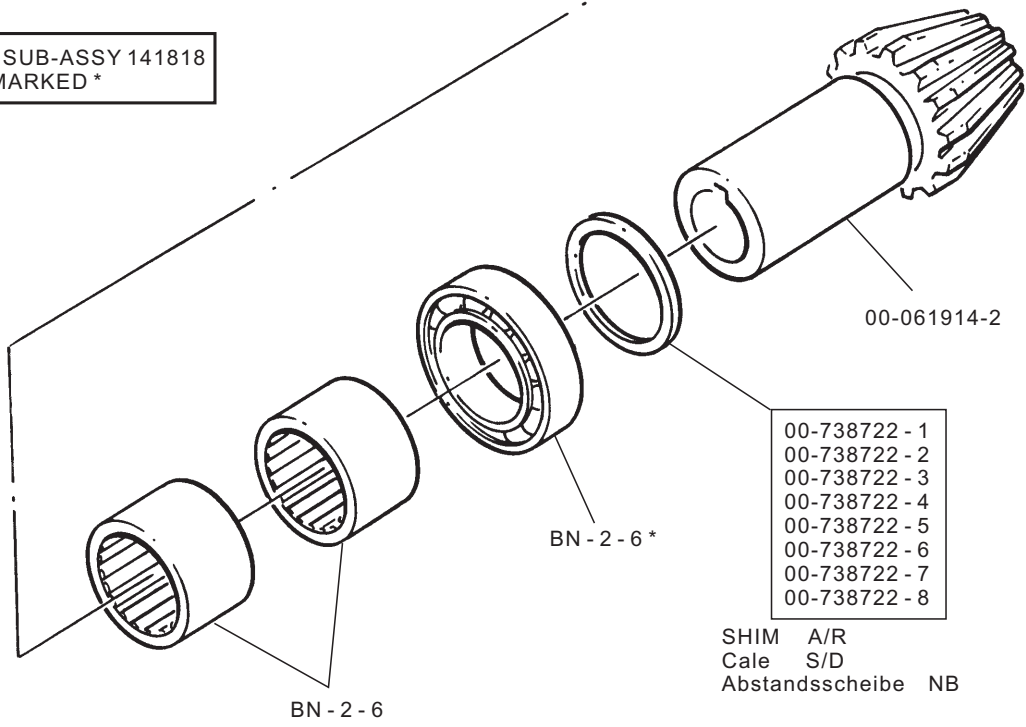



Shifting Unit Changement de vitesses Geschwindigkeitswahlschalter

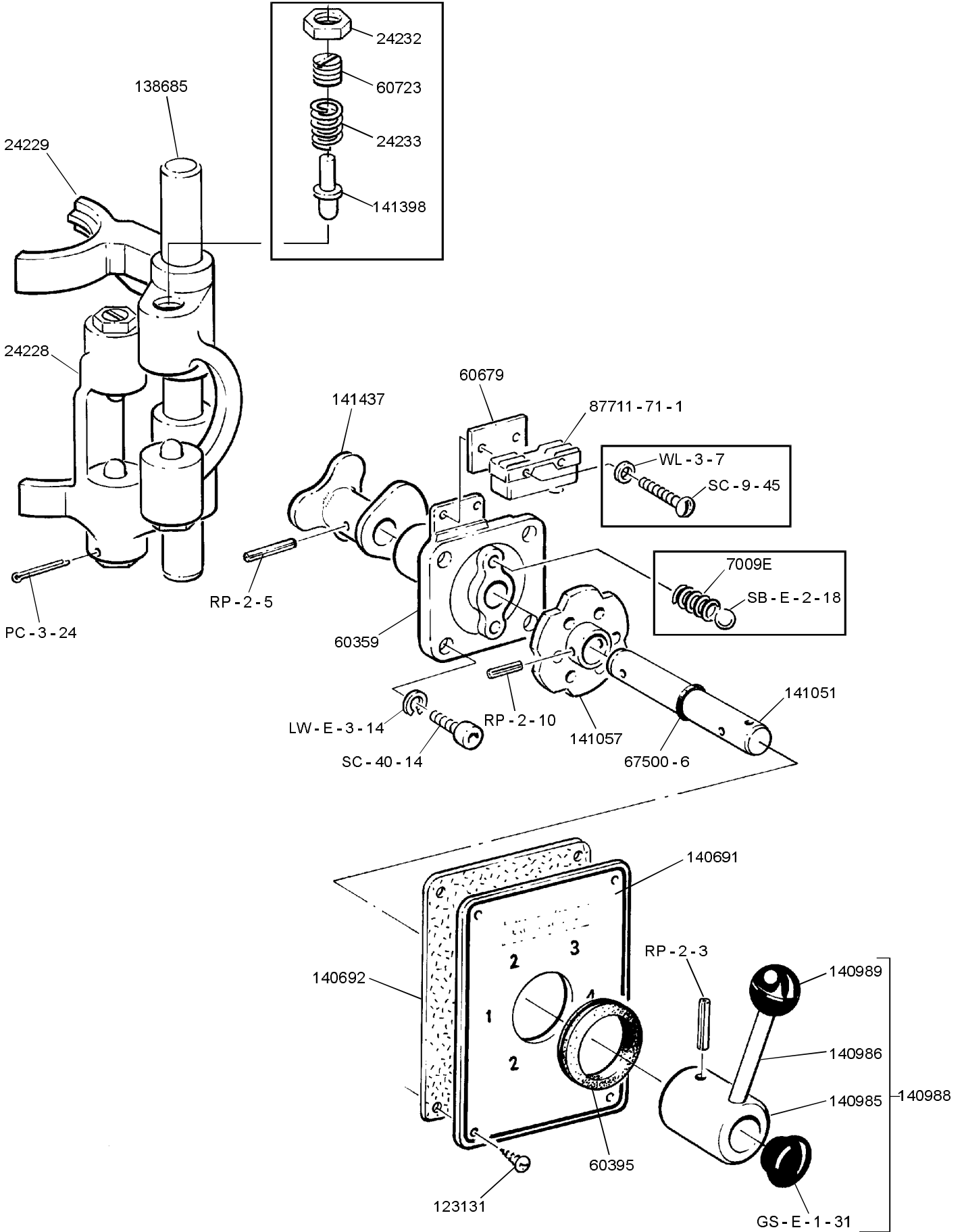

**Planetary Shaft
Planétaire arbe
Planetengetriebewelle**

**H600
H800**

00-738717-4	.150"
00-738717-5	.153"
00-738717-6	.156"
00-738717-7	.159"
00-738717-8	.162"
00-738717-9	.165"
00-738717-10	.168"
00-738717-11	.171"
00-738717-12	.174"

SHIMS - A/R

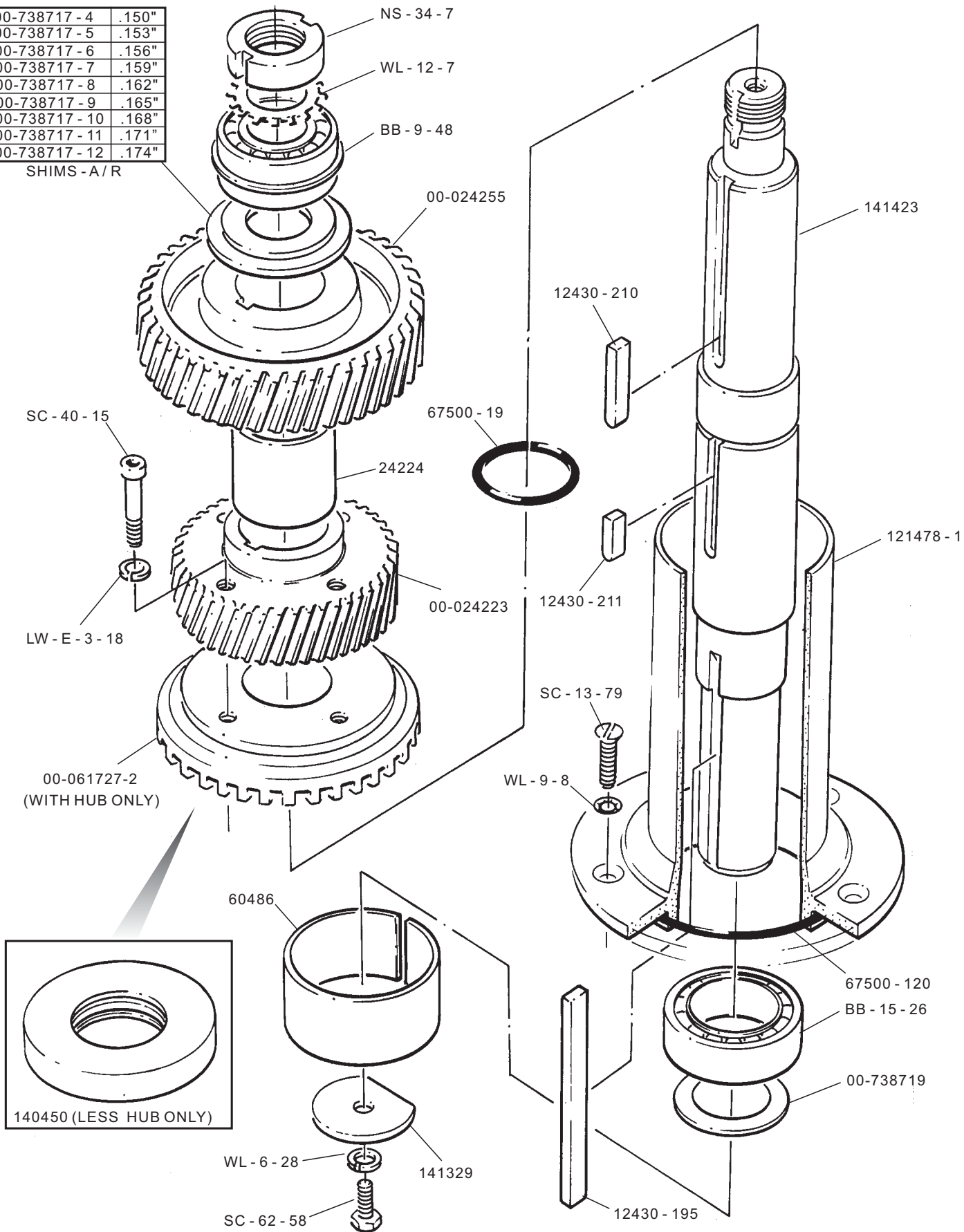

Clutch Shaft Arbre des clabots Kupplungswelle

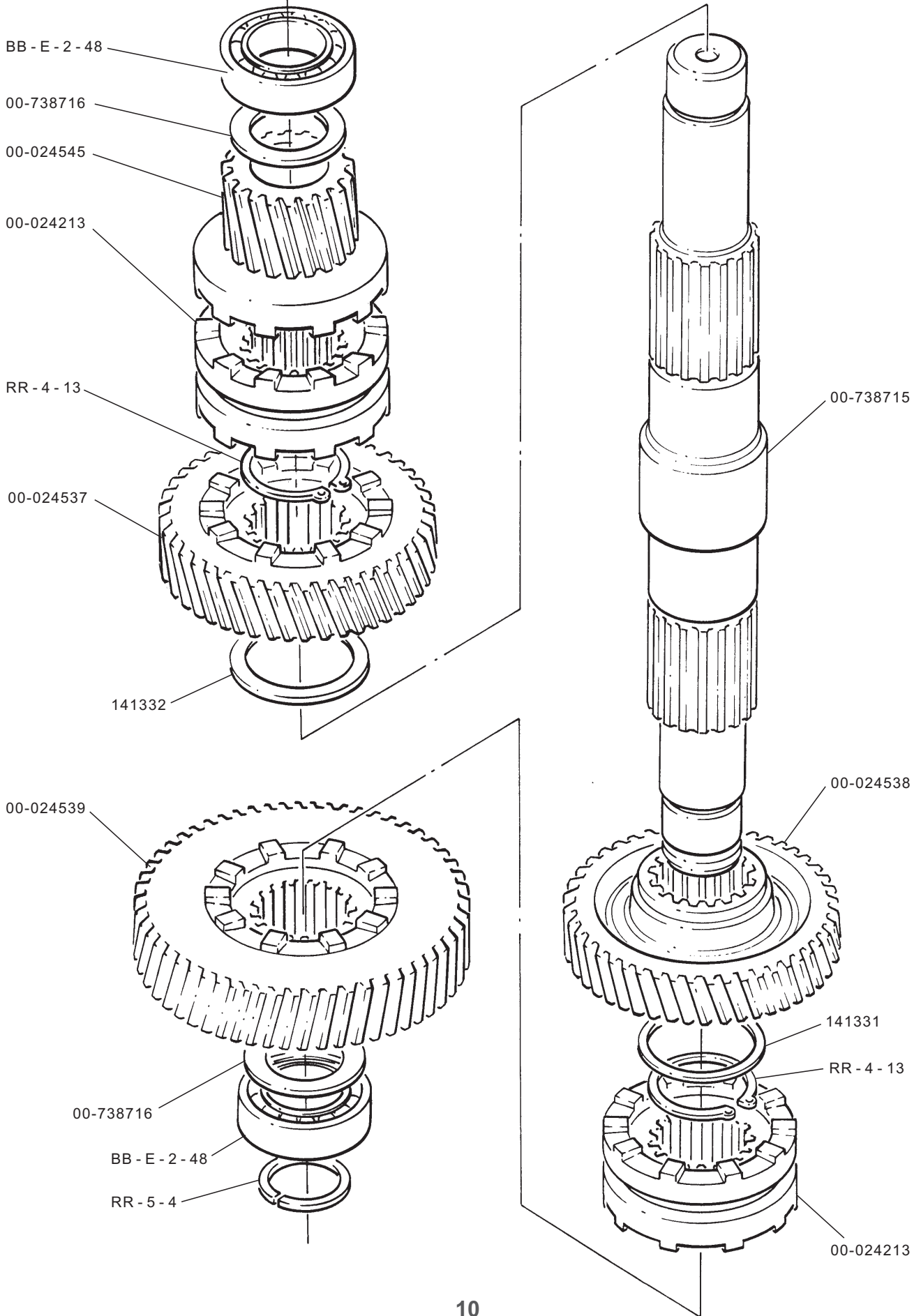

**Worm Gear Shaft
Arbre roue helicoidale
Schneckenradwelle**

**H600
H800**

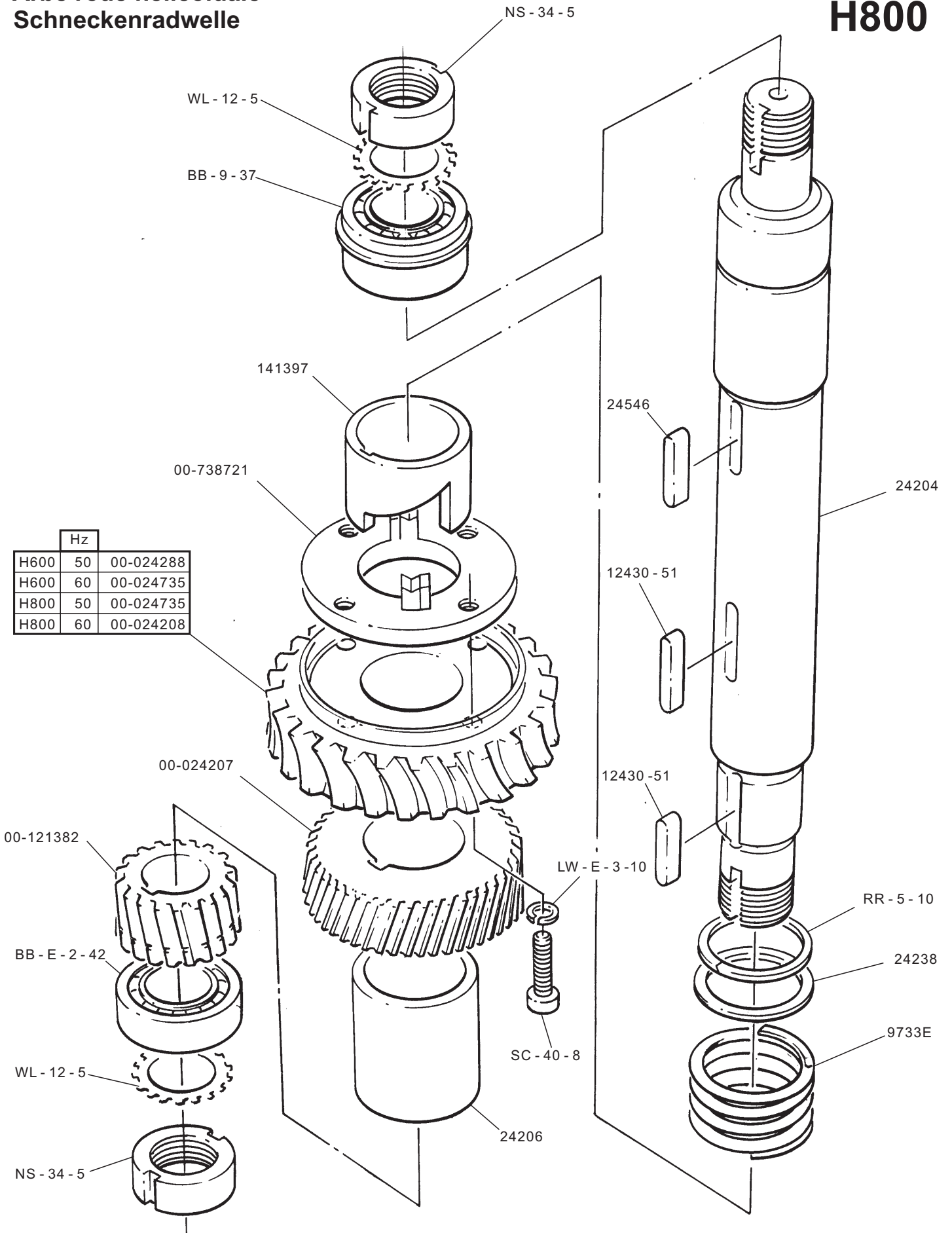

	Hz	
H600	50	00-024288
H600	60	00-024735
H800	50	00-024735
H800	60	00-024208

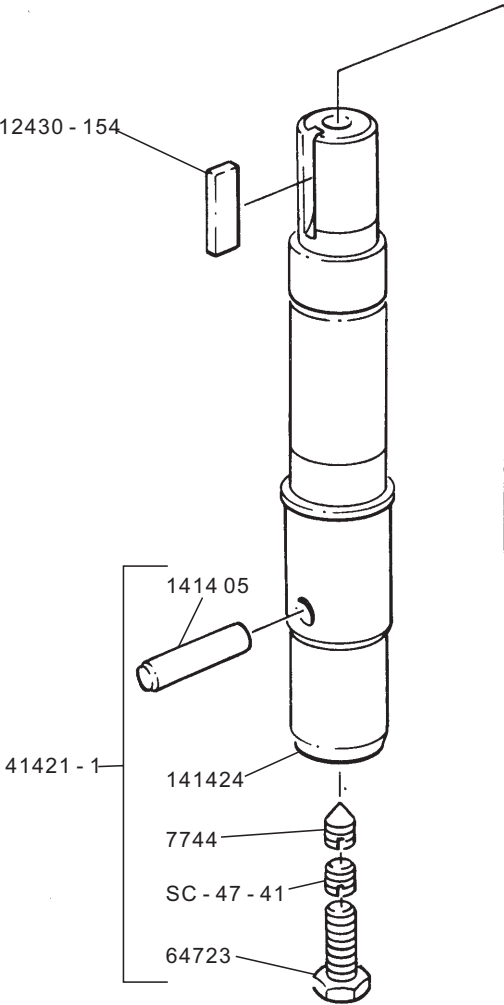
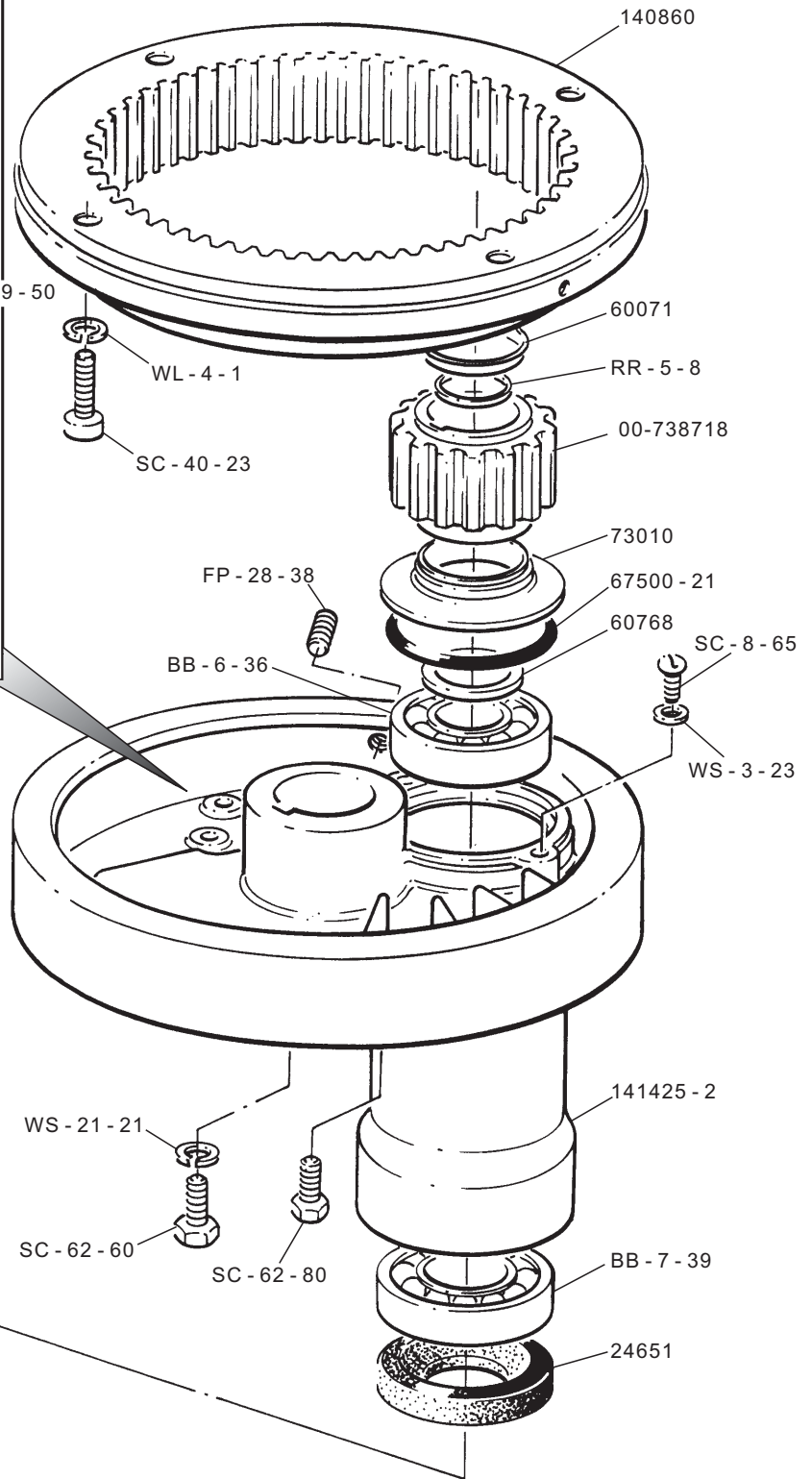
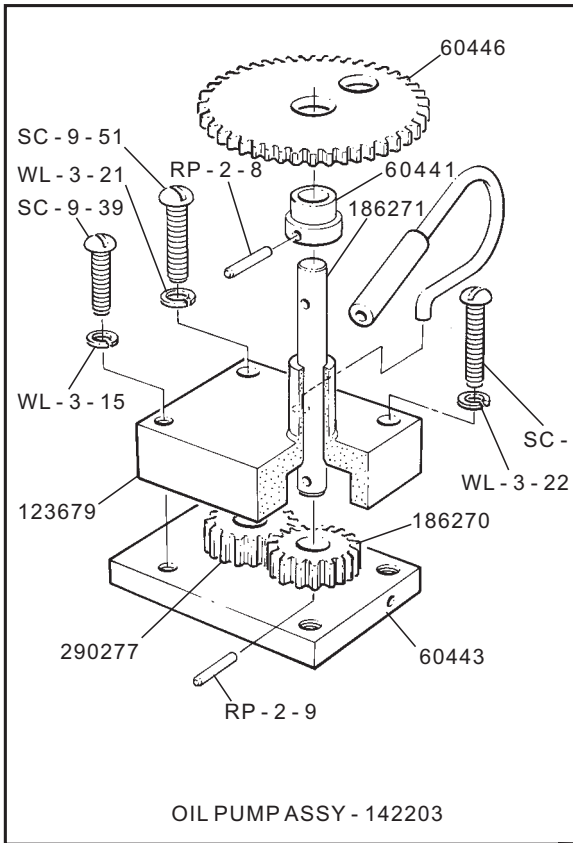

Guard Assembly
Sécurité de bol
Schutzgitter

H600 to MAY 01 Before 970160716
H800 to AUG 03 Before 970168636

H600
H800

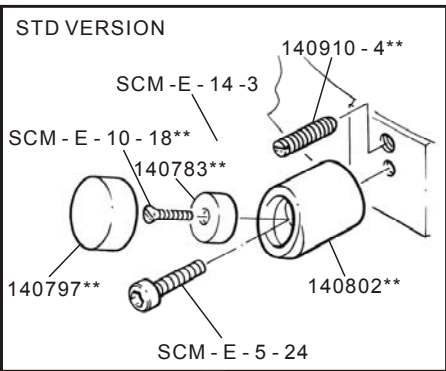
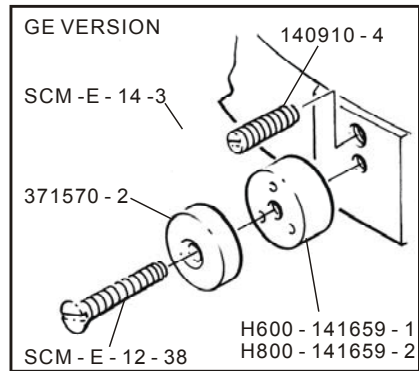
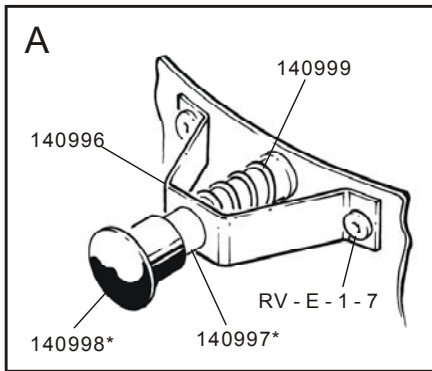

	mm
**141611-1	.12
**141611-2	.25
**141611-3	.37

SHIMSA/R

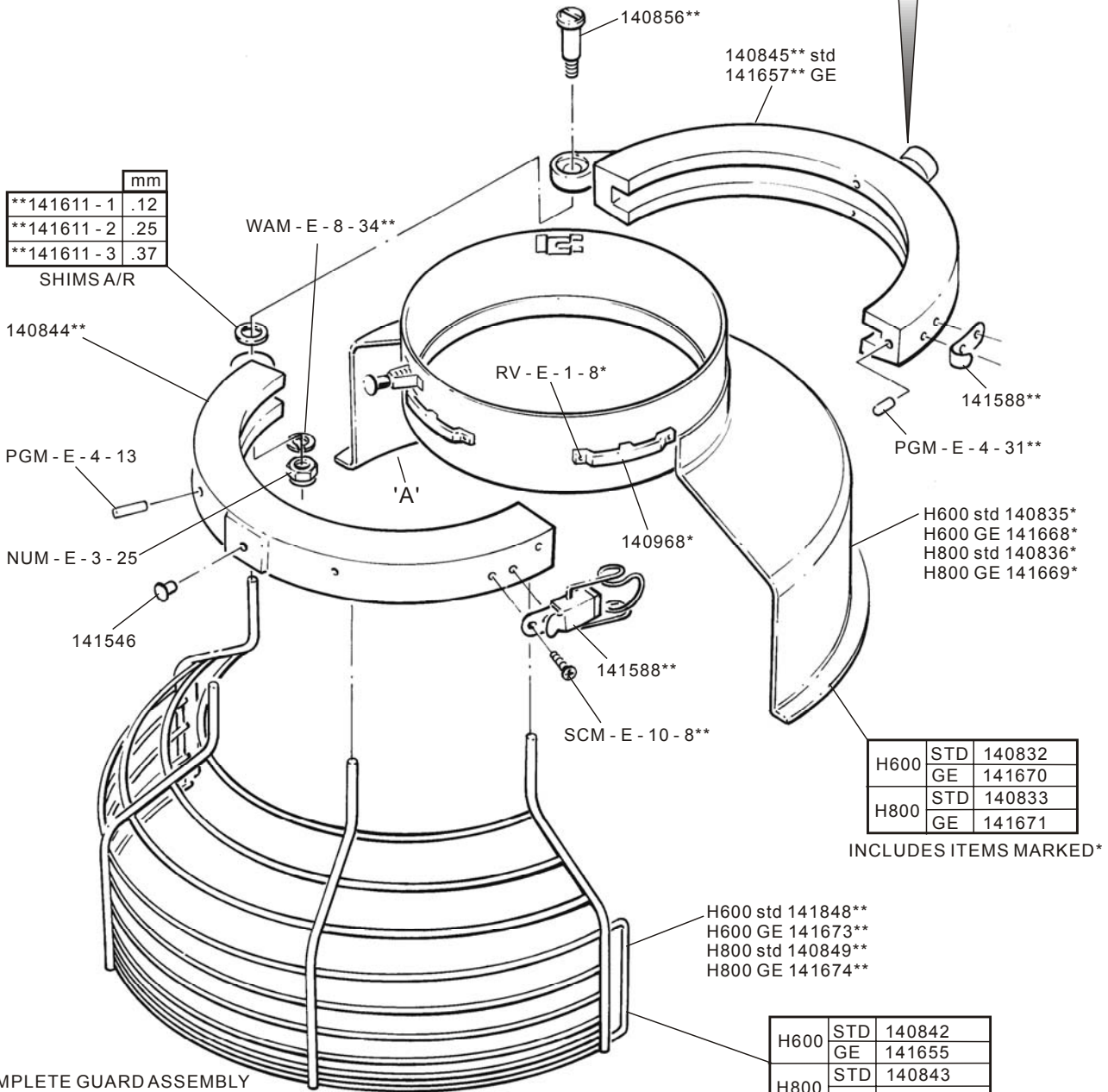

H600	STD	140832
	GE	141670
H800	STD	140833
	GE	141671

INCLUDES ITEMS MARKED*

H600 std 141848**
H600 GE 141673**
H800 std 140849**
H800 GE 141674**

H600	STD	140842
	GE	141655
H800	STD	140843
	GE	141671

INCLUDES ITEMS MARKED*

COMPLETE GUARDASSEMBLY

H600	STD	141826
	GE	141828
H800	STD	141827
	GE	141829

NOTE:-
SPLASH GUARD ASSY.
00 - 437450
INCLUDES ITEMS THUS*

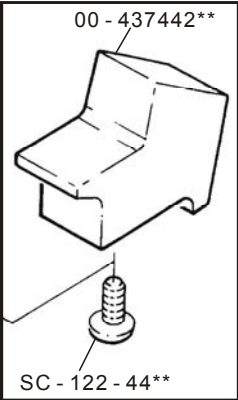
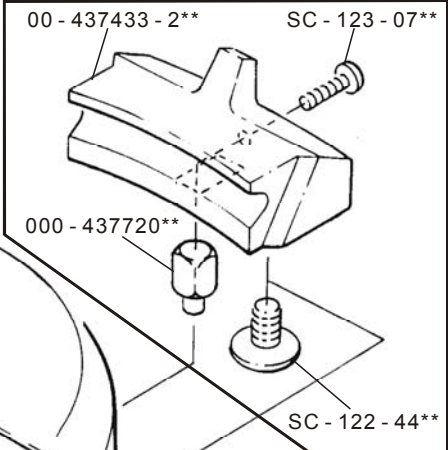
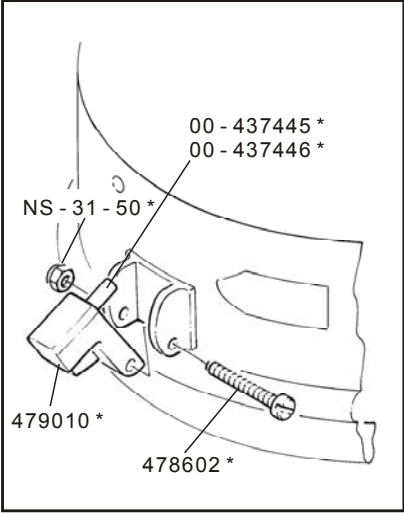

**PUSH HERE TO
TURE CAGE**

00 - 438712 *

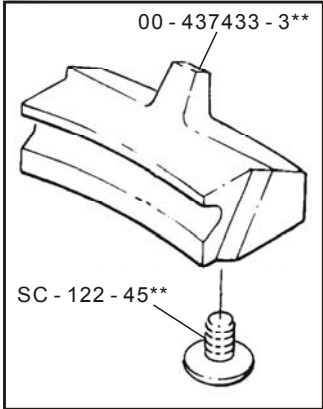
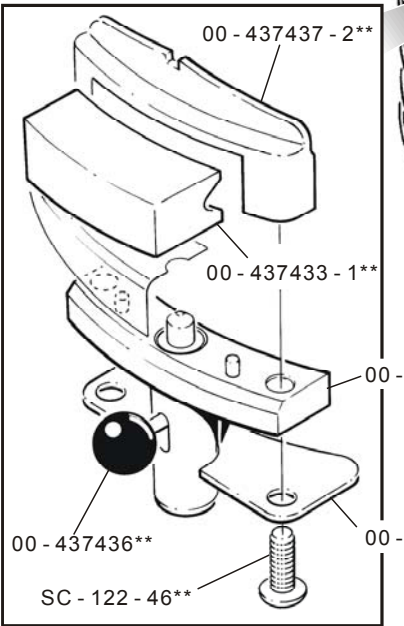
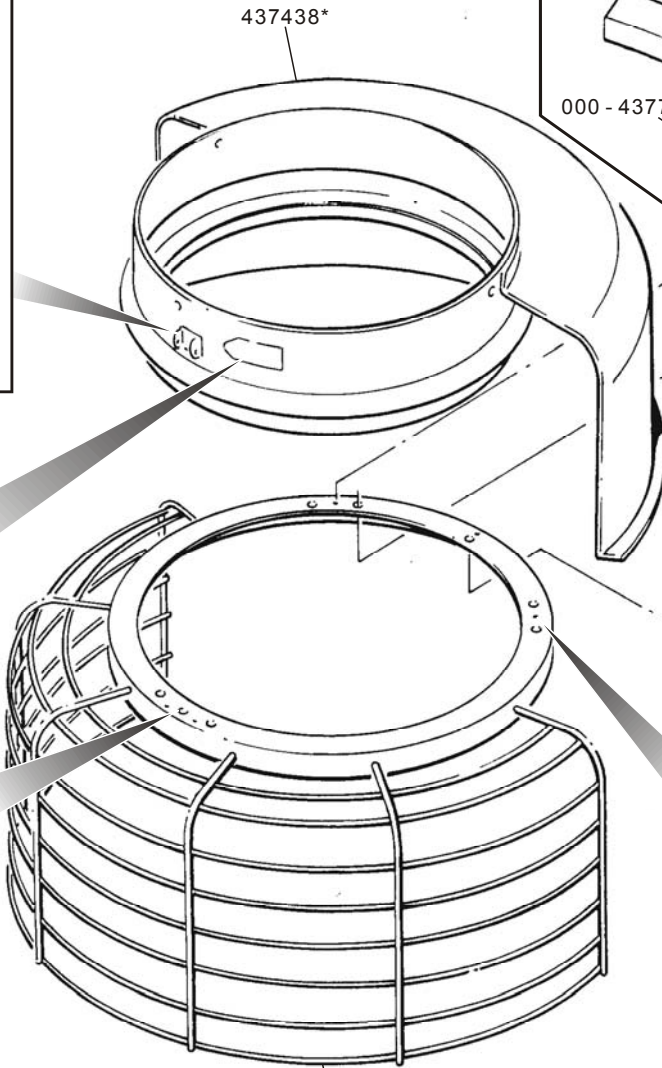

NOTE:-
CAGE ASSY. = 00 - 438160
INCLUDES ITEMS MARKED THUS**

Guard Assembly
Sécurité de bol
Schutzgitter

H600 from SEPT 03 970169049
H800 from AUG 03 970169636

H600
H800

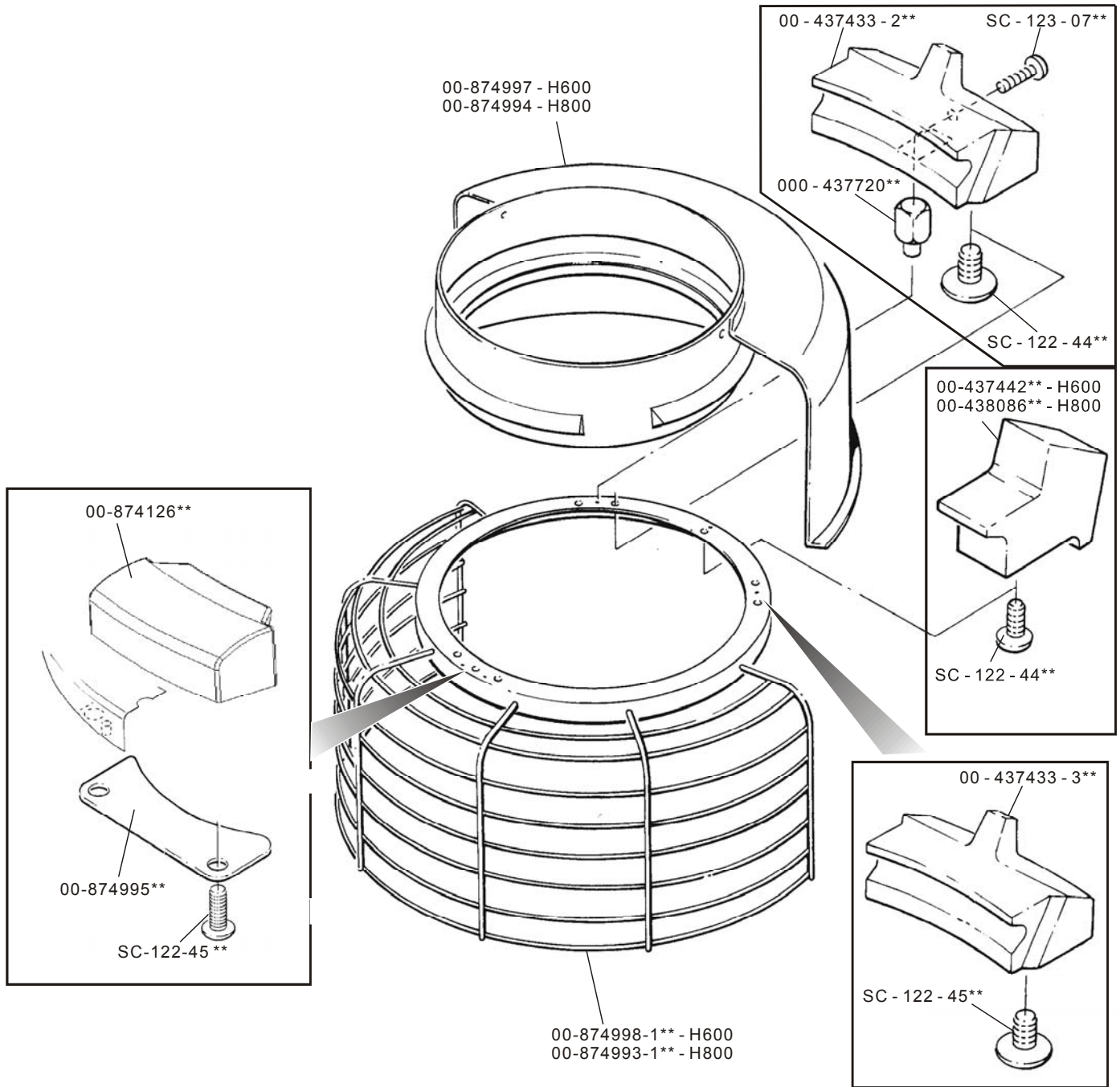

NOTE:-
CAGE ASSY. = 00-874999 - H600
CAGE ASSY. = 00-874992 - H800
INCLUDES ITEMS MARKED THUS**



Transmission case unit
Boîte de vitesses
Antriebsgehäuse

H600 TO MAY 01 Before 970160716
H800 TO AUG 03 Before 970168636

EG - UK & FRANCE

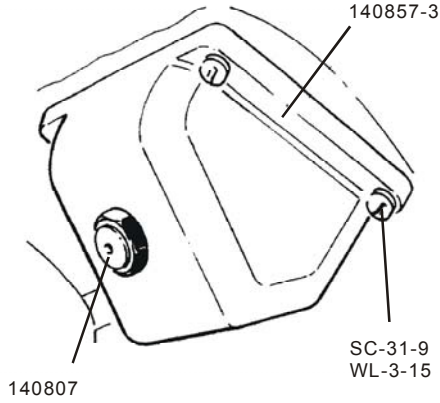

GUARD REF PAGE 13

GS - GERMANY

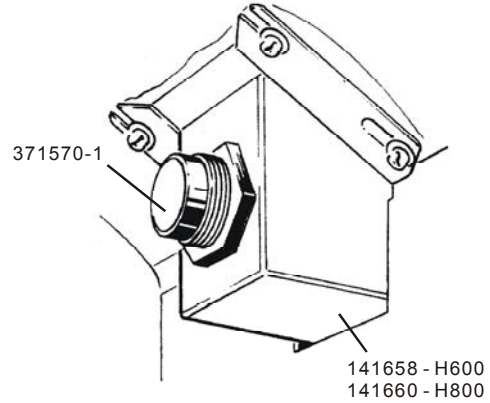

H600 FROM MAY 01 TO SEPT 03
970160716 TO 970169048

EG - UK & FRANCE

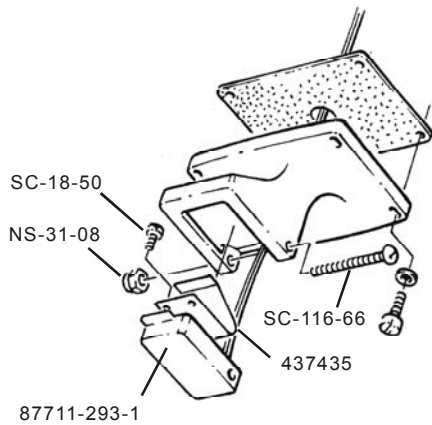

GUARD REF PAGE 14

H600 FROM SEPT 03 From 970169049
H800 FROM AUG 03 From 970168636

EG - UK & FRANCE

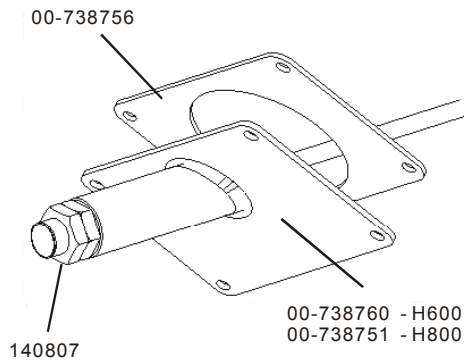

GUARD REF PAGE 15

	MBL	PBL
EP - E - 10 - 1	X1	X2
EP - E - 10 - 10	X1	X2

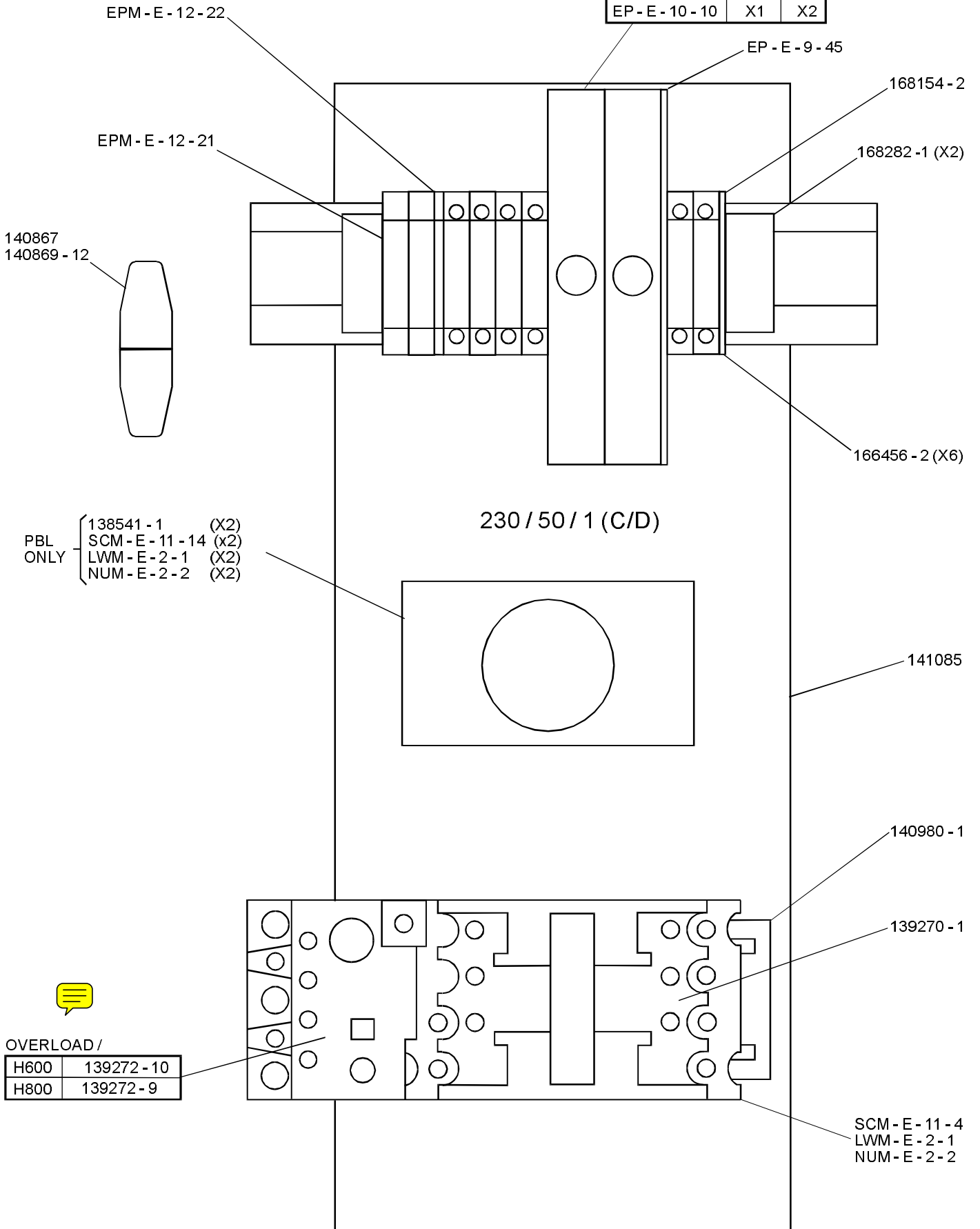



**Timer
Minuterie
Zeitschater**

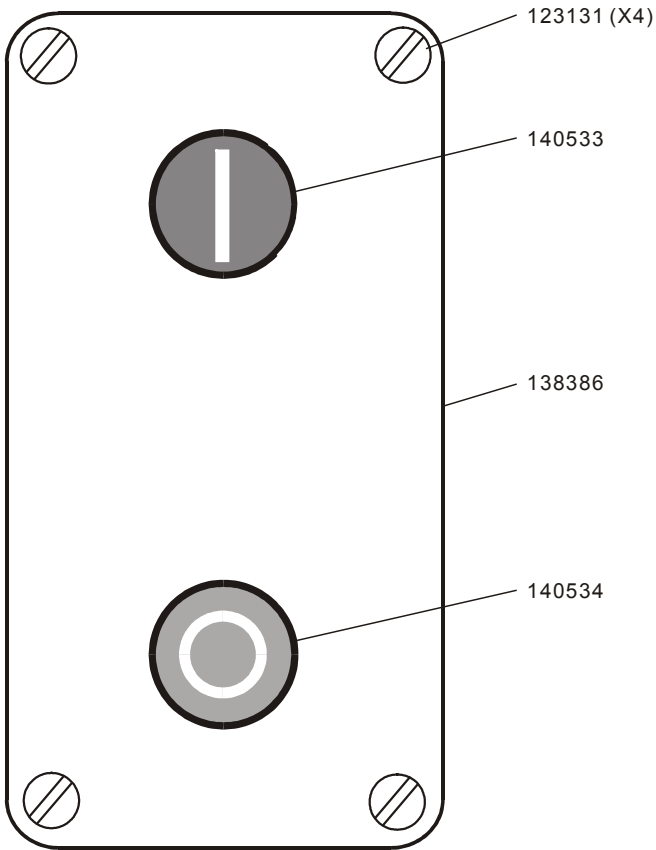

TIMER / Minuterie / Zeitschater	
15 min	SS - E - 18 - 10
30 min	SS - E - 18 - 11

Plate timer / Plaque minuterie Zeitschaterplatte	
15 min	139396
30 min	139869

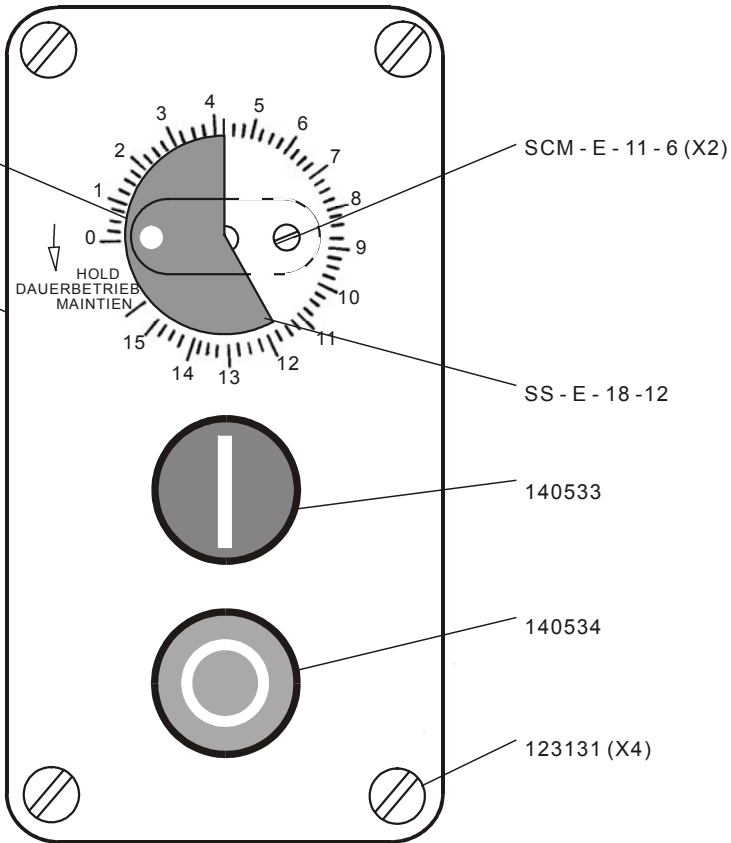

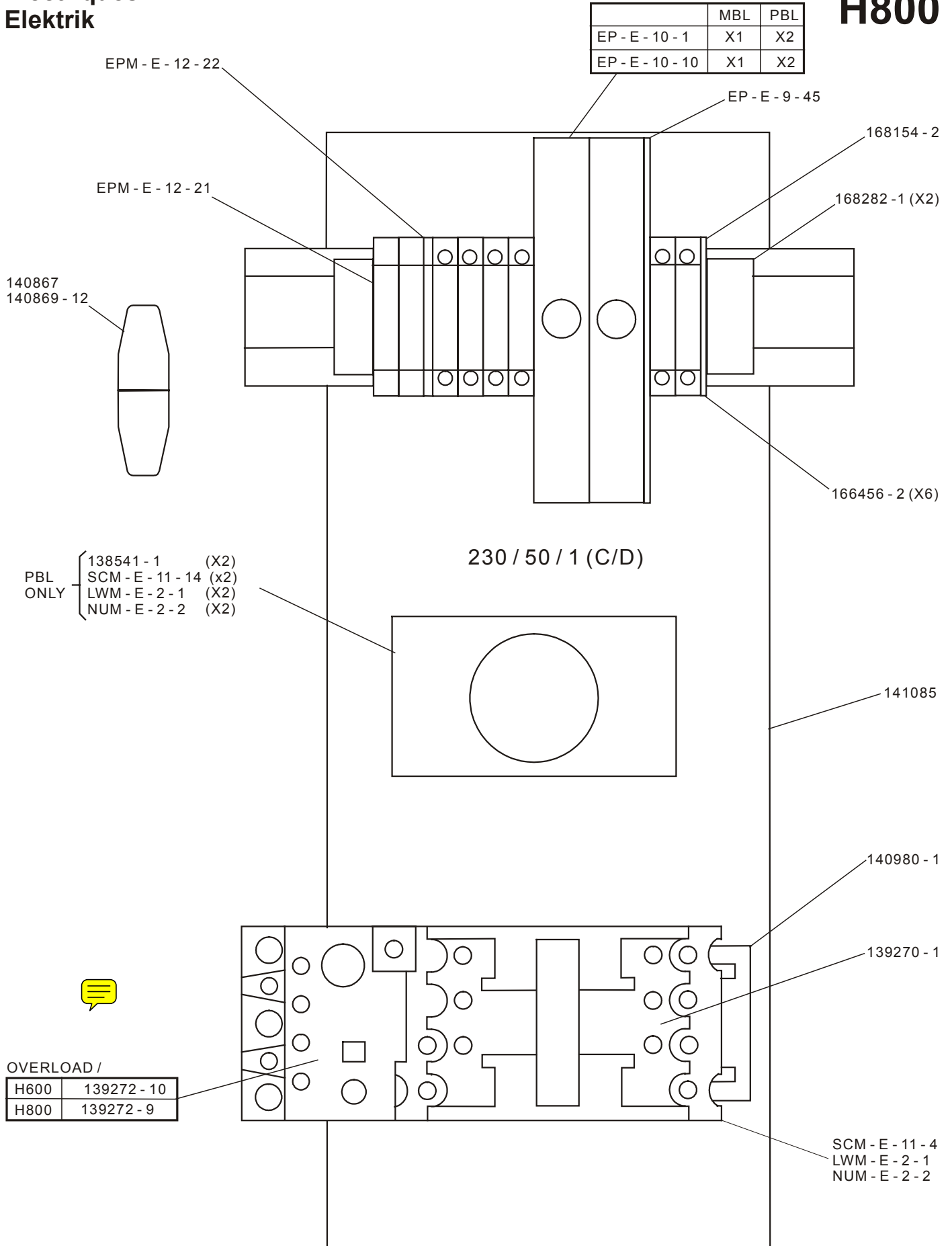



**Electrics
Électriques
Elektrik**

230 / 50 / 3 (F / G)
400 / 50 / 3 (H / S)
400 / 50 / 3 + (K / L)

H600 MBL EG H800	400 / 50 / 3
H600 PBL H800	400 / 50 / 3
	400 / 50 / 3 - 4
	230 / 50 / 3

EP - E - 10 - 1	X3	X6	X1	X2
EP - E - 10 - 10	X3	X6	X1	X2

SCM - E - 4 - 37
LWM - E - 2 - 35
NUM - E - 2 - 27

EP - E - 9 - 45

166456 - 2 (X7) 400 / 50 / 3
(X8) 400 / 50 / 3 - 4

168154 - 2

168282 - 1 (X2)

GERMANY ONLY
371568 - 1
142031 (X2)
SCM - E - 11 - 30 (X2)
NUM - E - 2 - 22 (X2)

140867
140869 - 12

57136 - 1
SCM - E - 3 - 8 (X2)
LWM - E - 2 - 1 (x2)
NUM - E - 2 - 22 (X2)
400 / 50 / 3 ONLY

140980 - 1

PBL ONLY

141440 - 11 (X2)
144251
SCM - E - 11 - 14 (X6)
LWM - E - 2 - 1 (X6)
NUM - E - 2 - 22 (X6)

SCM - E - 11 - 14 (X2)
LWM - 2 - 1 (X2)
NUM - 2 - 2 (X2)

OVERLOAD!

H600	139272 - 8	400 / 50 / 3
H800	139272 - 9	400 / 50 / 3 - 4
H600		230 / 50 / 3
H800		400 / 50 / 3 - 4

141085

Bowls and Equipment
Bols et Équipement
Kessel und Ausrüstung

H600
H800

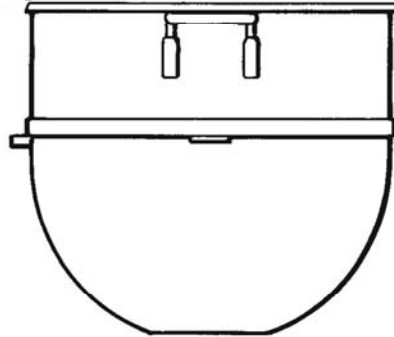

	H600	H800
30qt S/S BOWL	295648	-
40qt BOWL	295650	-
40qt S/S BOWL	275686	275686
60qt S/S BOWL	66462	-
80qt S/S BOWL	-	59780

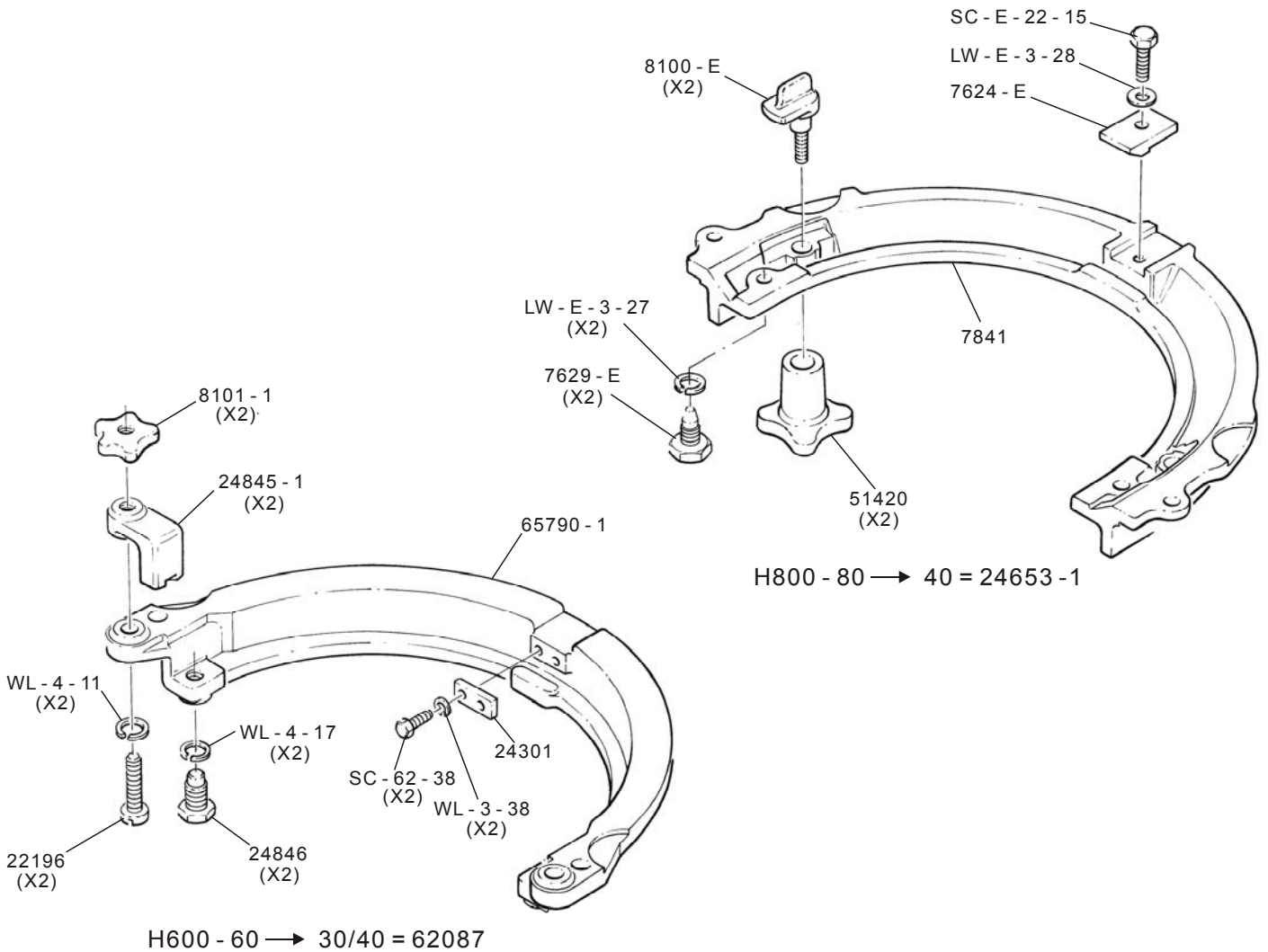



Agitators
 Agitateurs
 Rührwerkzeuge

H600
 H800

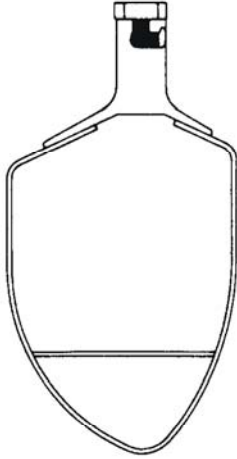

	H600	H800
30qt	275159	-
60qt	68096	-
80qt	-	52396



	H600	H800
40qt EB	295176	-
60qt ED	141430	-
40qt M	-	8151 - E
80qt ED	-	141431

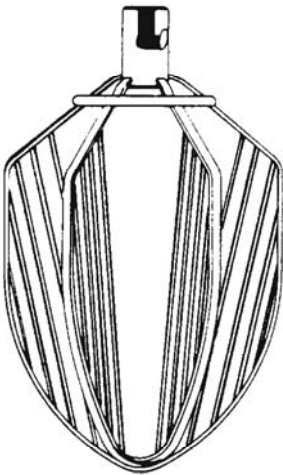

	H600	H800
40qt	275159	-
60qt	295156	-
80qt	-	53339

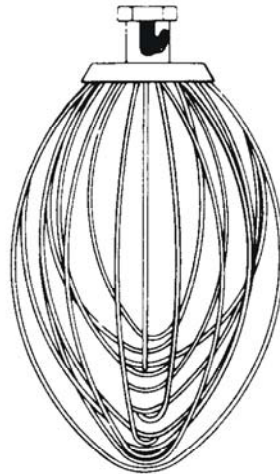

	H600	H800
30qt	295031	-
40qt	9006 - E	9006 - E
60qt	-	-
80qt	-	52912

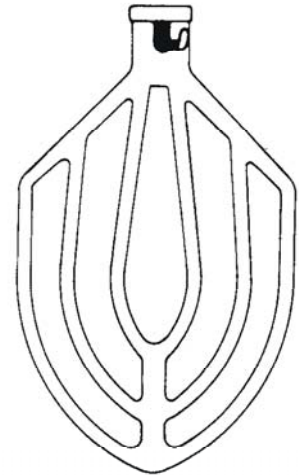

	H600	H800
30qt	275809	-
40	12108 - E	12108 - E
40qt s/s	55662	55662
60	141429 - 1	-
60qt s/s	141429 - 2	-
80	-	52312
80qt s/s	-	53309

SERVICE

Hobart trained service technicians strategically located at the listed Hobart branches are prepared to give you fast, efficient and reliable service. Protect your investment by having a Hobart inspection contract, which assures the continued, efficient operation of your Hobart machines, spares and accessories.

For further details contact:-

SALES: 07002 101 101
SERVICE: 07002 202 202
SPARES: 07002 303 303

Continued product improvement is a Hobart Still policy, specifications may change without notice.

Hobart ayant une politique d'amélioration constante de ses produits, les spécifications peuvent changer sans préavis.

Unsere Produkte werden ständig verbessert. Deshalb behält sich Hobart Still Änderungen der technischen Daten ohne Vorankündigung vor.

Hobart UK
Hobart House, 51 The Bourne,
Southgate, London N14 6RT
Tel: 020 8920 2800 Fax 020 8886 0450
www.hobartmfg.co.uk