

DP1080

PARTI DI RICAMBIO
PIECES DETACHEES
SPARE PARTS
ERSATZTEILE
LISTA DE RECAMBIOS

C 34

03/94

10 - 1998 S. AG.

C34

Hood

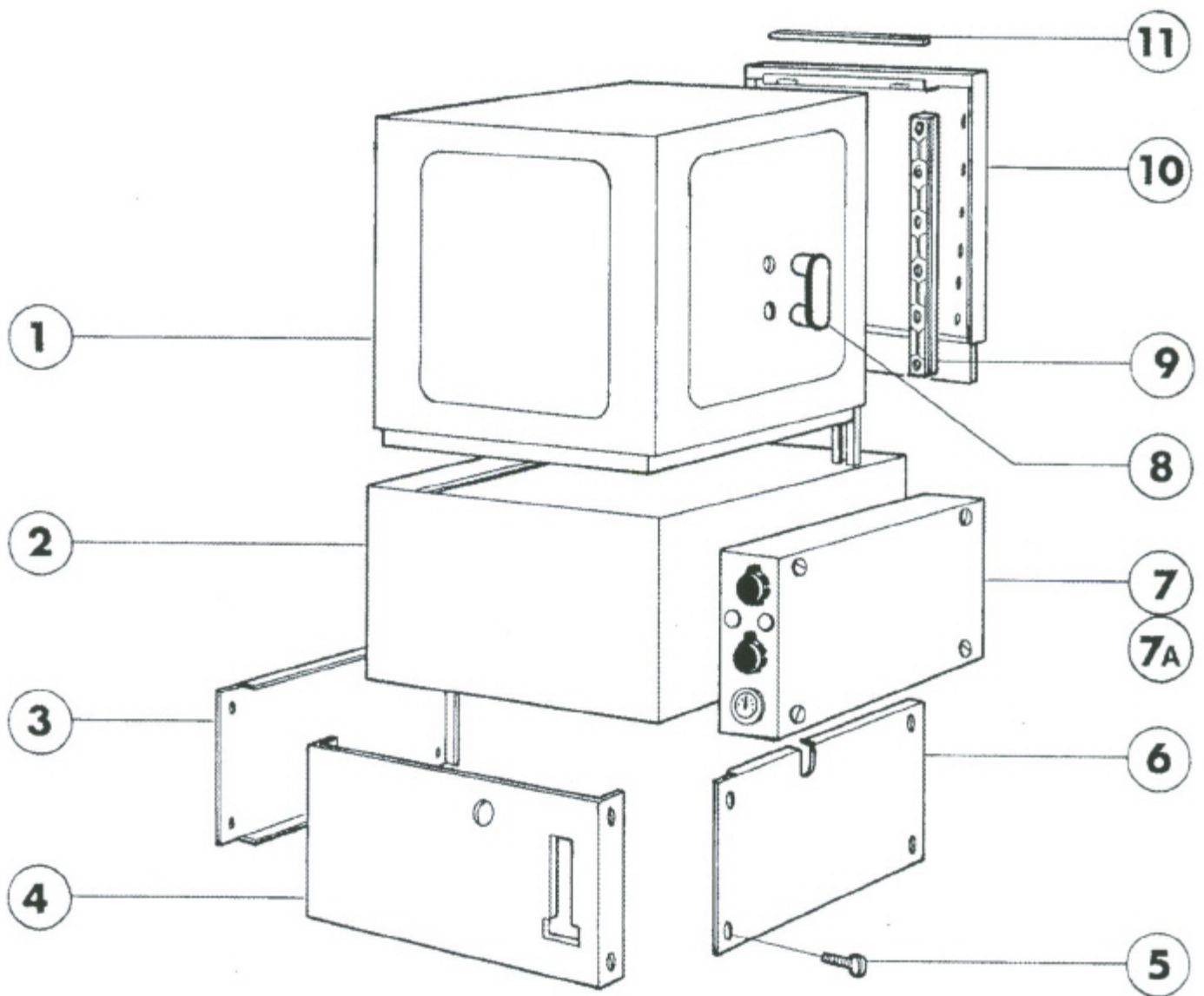

C34**Hood**

CODE	DESCRIPTION	PRICE (Eur)
110130	WIRING FOR C34 2"	0.00
110134	WIRING FOR C34 STEAM	0.00
180604	GUIDE F. HOOD C33-34 GRAY	0.00
190608	GUIDE FOR DOOR C30-C140	0.00
200432	SPONGY RUBBER ADHESIV 8X4 NEOPRENE	0.00
260223	M5X12 MSH/HD SCREW SPECIAL S/S	0.00
340142	HOOD C34 II	0.00
340312	SUPPORT	0.00
340851	TANK C34 2aS	0.00
350171	FRONT PANEL C34 2a	0.00
350264	RIGHT PANEL C34 2a	0.00
350265	LEFT PANEL C33-34 2a	0.00

C34

Handle

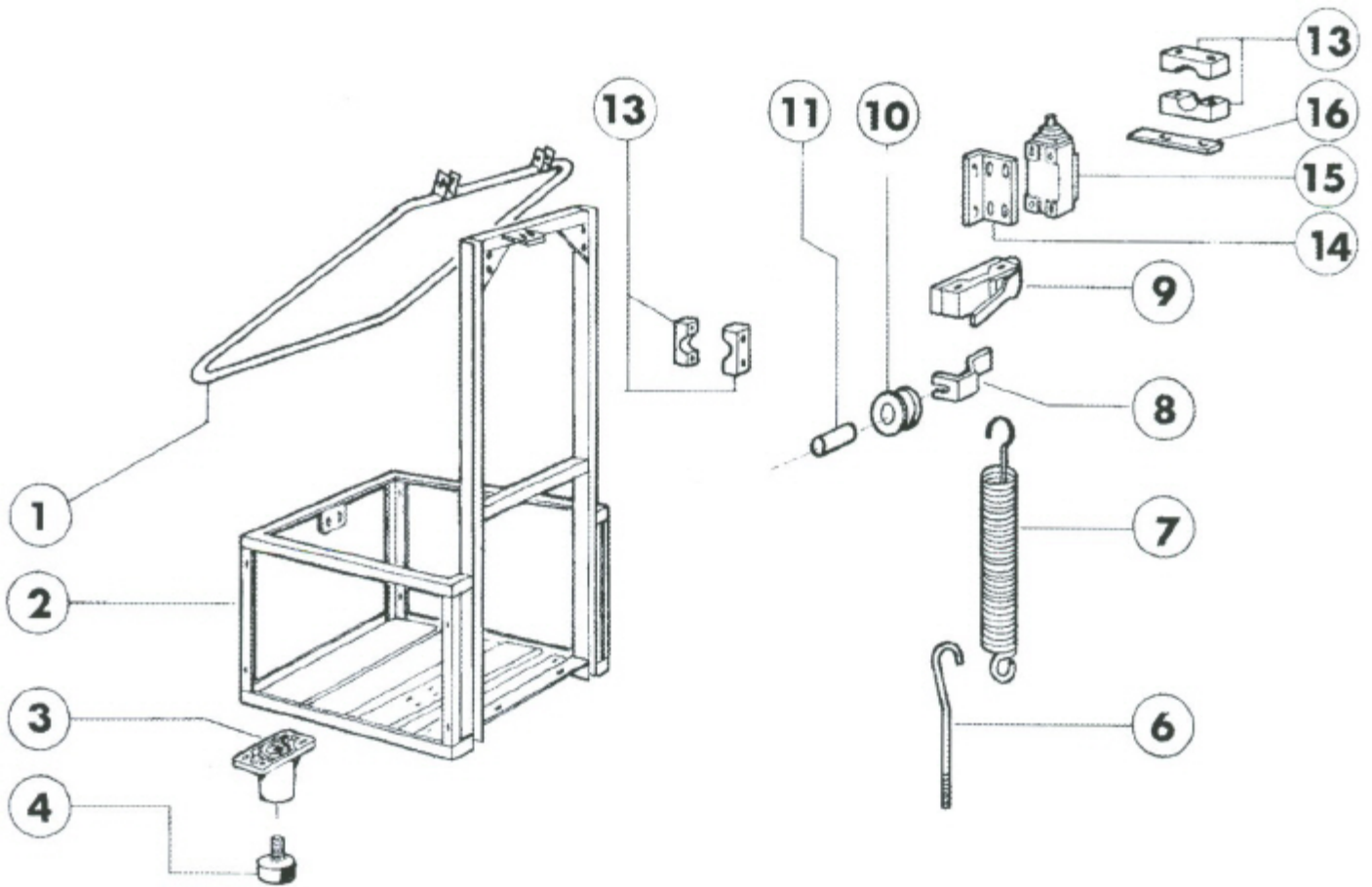

C34
Handle

CODE	DESCRIPTION	PRICE (Eur)
120319	MICRO SWITCH OMR.C34	0.00
120322	LIMIT SWITCH FD101 + MICRO M1 +P91	0.00
160509	FOOT SUPPORT	0.00
190616	DOOR SPRING ROLLER C34 HOST	0.00
210203	RUBBER FOOT 30 MM	0.00
320644	PLATE MICROSWITCH C34	0.00
330207	LOWER TIE ROD SPRING C34	0.00
330816	BUSHING DOOR HING.F2-45-5 STAINL.ST	0.00
331007	HANDLE C34 II	0.00
350742	BRACKET FOR MICRO HOOD C34-C140	0.00
390272	FRAME	0.00
391313	SPRING F.DOOR LEVER C34	0.00
440703	BLOCK F. MICROSWITCH C34 D23	0.00

C34

Tank

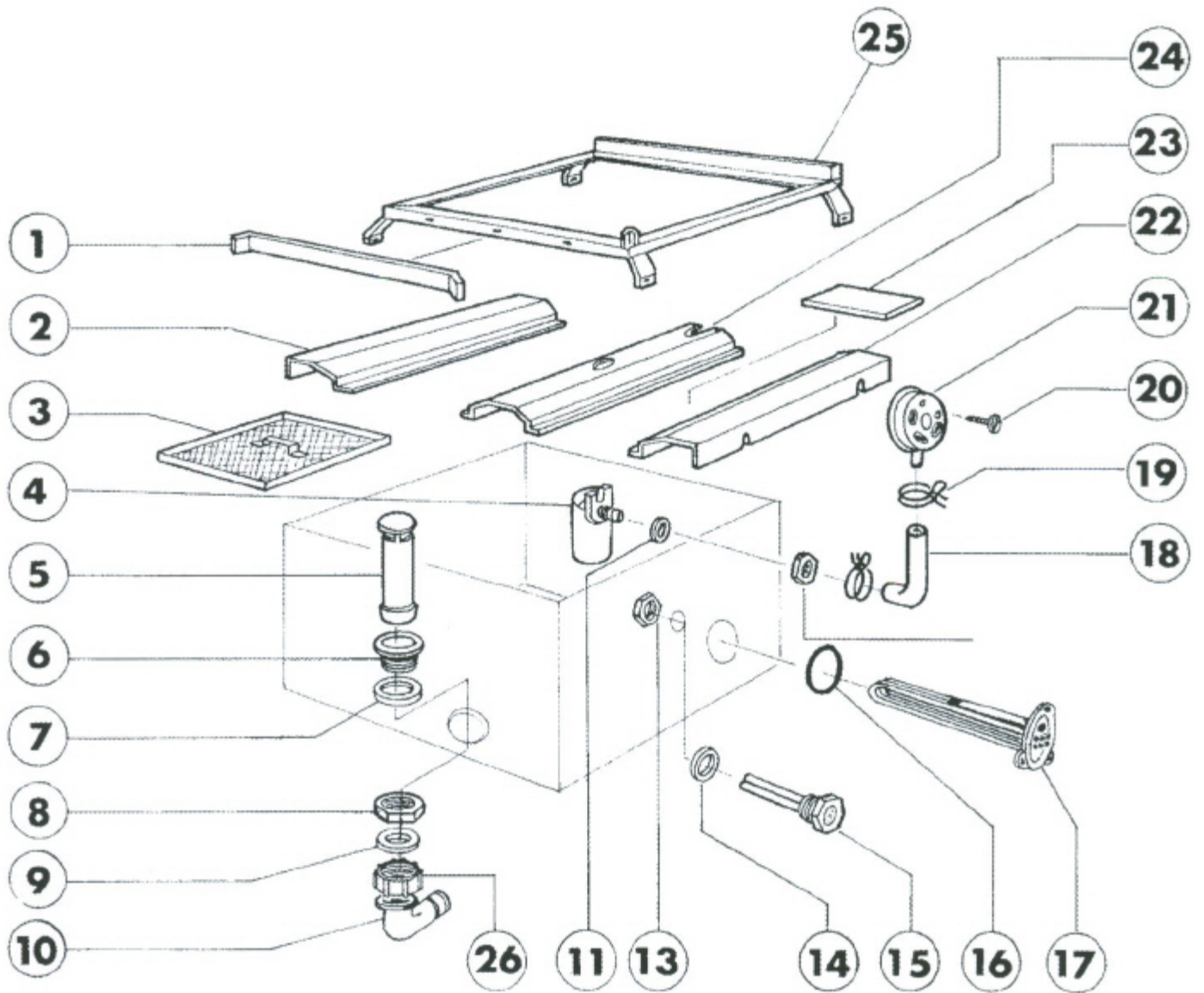

C34
Tank

CODE	DESCRIPTION	PRICE (Eur)
110226	HEAT. ELEMENT 3000W 230/400V	0.00
130604	PRESSURE SWITCH 80-50 1 LEVEL	0.00
160202	ELBOW 2 DIAMETERS	0.00
160305	DRAIN OUTLET 1"1/2 C-S-N	0.00
161301	AIR TRAP F2 C34-F45	0.00
180102	DRAIN PIPE NUT 1"1/2 F45-55	0.00
180109	LOCK NUT 1 1/2"	0.00
180703	OVERFLOW STANDPIPE 215 C34- S90-S	0.00
180811	FLAT STRAINER C34-S1600	0.00
200353	PRESS.SWITCH HOSE B23-10-1-2-C34	0.00
200410	DRAIN OUTL.WASH.1 1/2*65X47X2	0.00
200412	GASKET DRAIN 1 1/2" 45X33X3	0.00
200415	AIR TRAP GASKET -F2 18,5X10X3	0.00
200815	O-RING F. HEAT.ELEM.	0.00
260701	SCREW 3,5X9,5	0.00
270101	HEXAGON LOCK NUT 1/2"	0.00
320891	DOOR GUIDE C34	0.00
320892	BRACKET	0.00
321003	GUIDE	0.00
321004	GUIDE	0.00
321005	GUIDE	0.00
321009	GUIDE	0.00
450125	ELASTIC CLAMP D. 10,4X9,8	0.00
450514	THERMOSTAT SHIELD DOUBLE (450516)	0.00
460502	GASKET 30X21X2 C34-R ASBESTOS	0.00

C34

Wash

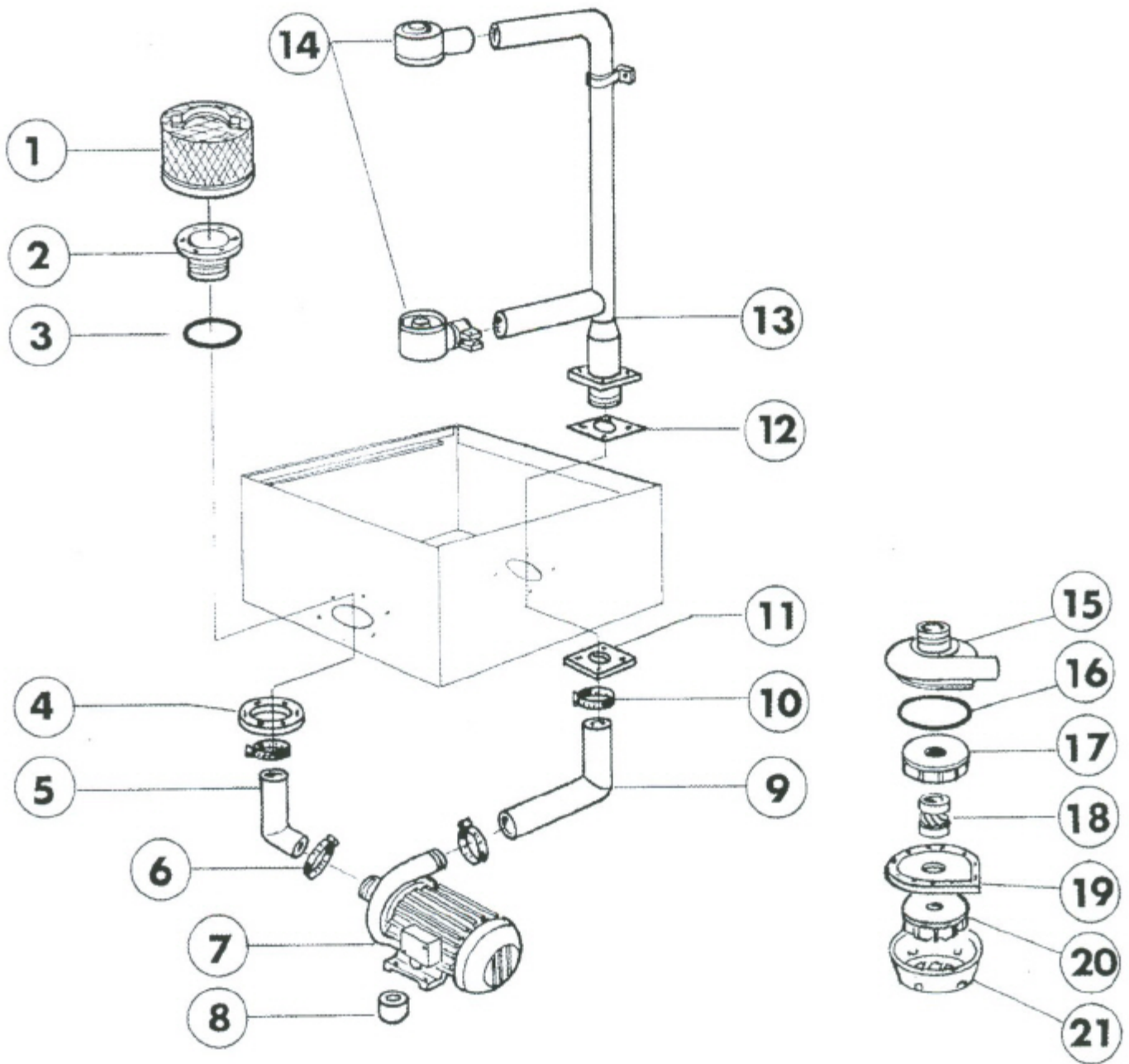

C34
Wash

CODE	DESCRIPTION	PRICE (Eur)
100361	PUMP HP 2 F 220/380 50HZ-1204	0.00
180204	COUNTERFLANGE D.130 SUCTION N S	0.00
180207	SUCTION FLANGE C33/34	0.00
200315	OUTLET HOSE C34-35	0.00
200359	INLET HOSE C34-S	0.00
200423	GASKET TUBE 100X100 HOLE48,5X3	0.00
200807	O-RING 3.53 X 110,72	0.00
210202	RUBBER FOOT GLASSWASHER	0.00
330528	STRAINER D.195 SNL C140	0.00
380904	BRASS FLANGE WASH. C34	0.00
420304	UPP/LOW WASH TUBE C34	0.00
450119	CLAMP FE ZN. 58-75 H=12,2	0.00
450127	CLAMP FE ZN. 68-85 H=12,2	0.00
510238	NICKEL-PLATED WASH-RINSE ARM C140	0.00
630114	VOLUTE FI HP2-2,7-3-3,2 12	0.00
630216	FAN HOUSING FI HP 2-3	0.00
630226	POST. PUMP FLANGE HP2 LS23	0.00
630306	PUMP FAN IMPELLOR FI HP.2-3	0.00
630411	O-RING PUMP FI HP 2-2,7	0.00
630501	SEAL FOR PUMP HP 2-3-3,2	0.00
631618	IMPELLER PUMP F HP2-D.116,5	0.00

C34
Rinse assembly

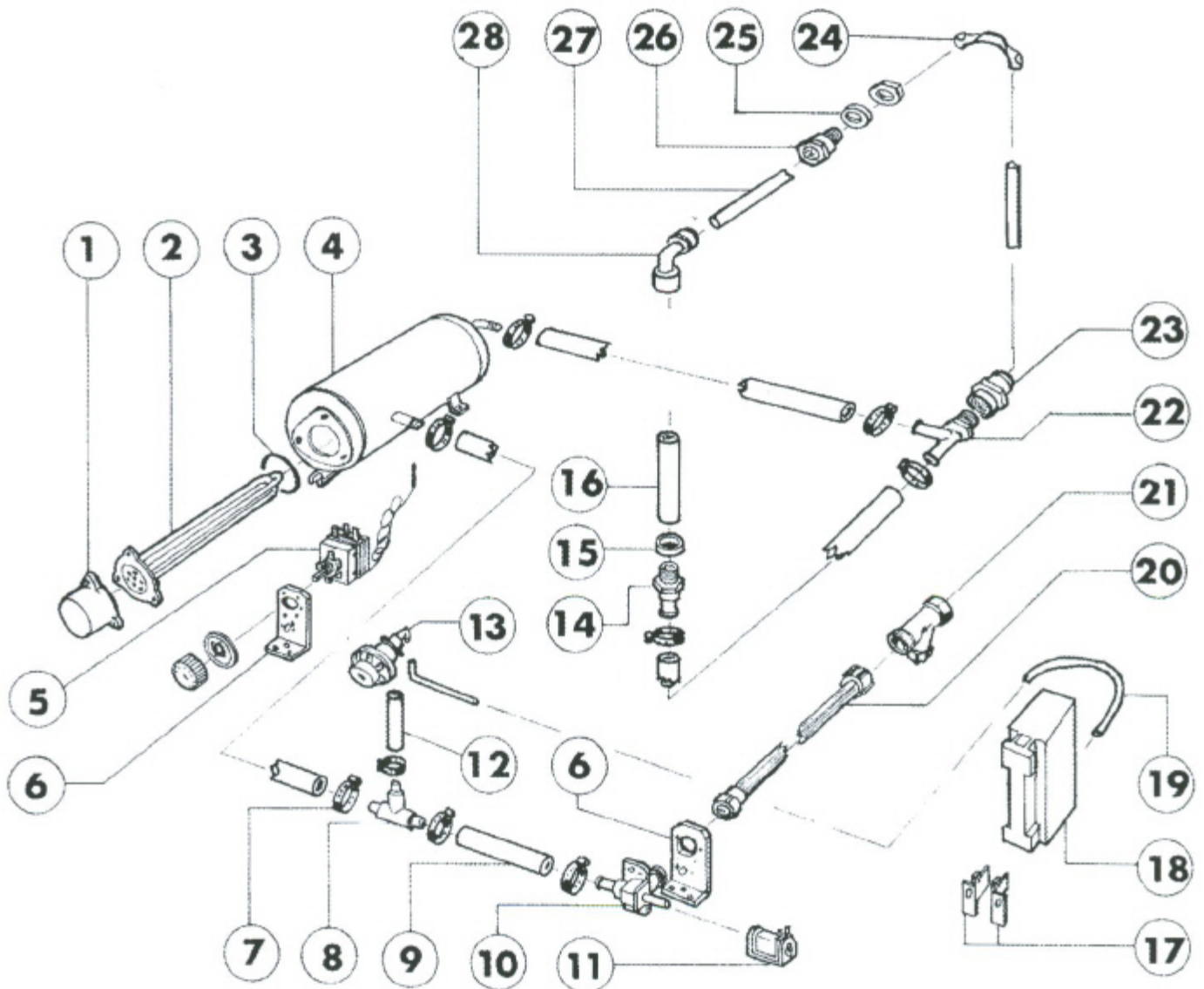

C34
Rinse assembly

CODE	DESCRIPTION	PRICE (Eur)
110349	HEAT ELEMENT 6000W 220/380V	0.00
120145	SOLENOID VALVE F2 14 LT/N 1 WAY	0.00
120501	THERMOSTAT 30/90° MT 1 TR/2	0.00
150811	CABLE HOLDER NYLON 1/2"	0.00
160105	INJECT.INLET HOSE D.6X4	0.00
160113	TUBE IN POL. RETIC. 12 EST	0.00
161102	ELEMENT COVER MOPL.	0.00
180408	TEE-NIPPLE F.INJECT.W/CENTR.REDUC.	0.00
190311	TEE RINSE C33/34	0.00
190804	RINSE AID CONTAINER F3 C30-C34	0.00
200113	RUBBER HOSE 12 X 22	0.00
200373	INJECTOR HOSE B20/27 7X16X190	0.00
200715	HOSE WATER INLET 2M STAINL.ST	0.00
200815	O-RING F. HEAT.ELEM.	0.00
200819	O-RING 17,13X21,65 3068	0.00
290216	HOSE CLAMPS STRAIGHT 12X1/2"	0.00
290217	HOSE CLAMP ELBOW 12X3/8" TYPE P4LF	0.00
290407	NIPPLE 3/8"	0.00
330307	BOOSTER	0.00
330725	STANDARD BRACKET F.SOLEN.VALV	0.00
331327	TUBE LOW.RINSE C33-34	0.00
350745	RIGHT BRACKET RINSE AID CONTAINER	0.00
390623	CURVED TUBE SUPPORT D.12	0.00
450104	CLAMP FE ZN H=12,5 15-24	0.00
460501	GASKET 24X17X2 C34-R ASBESTOS	0.00
620120	RINSE AID INJECTOR	0.00
620209	INLET WATER FILTER	0.00
630969	COIL S4216 220/50HZ	0.00

C34
Wash arm

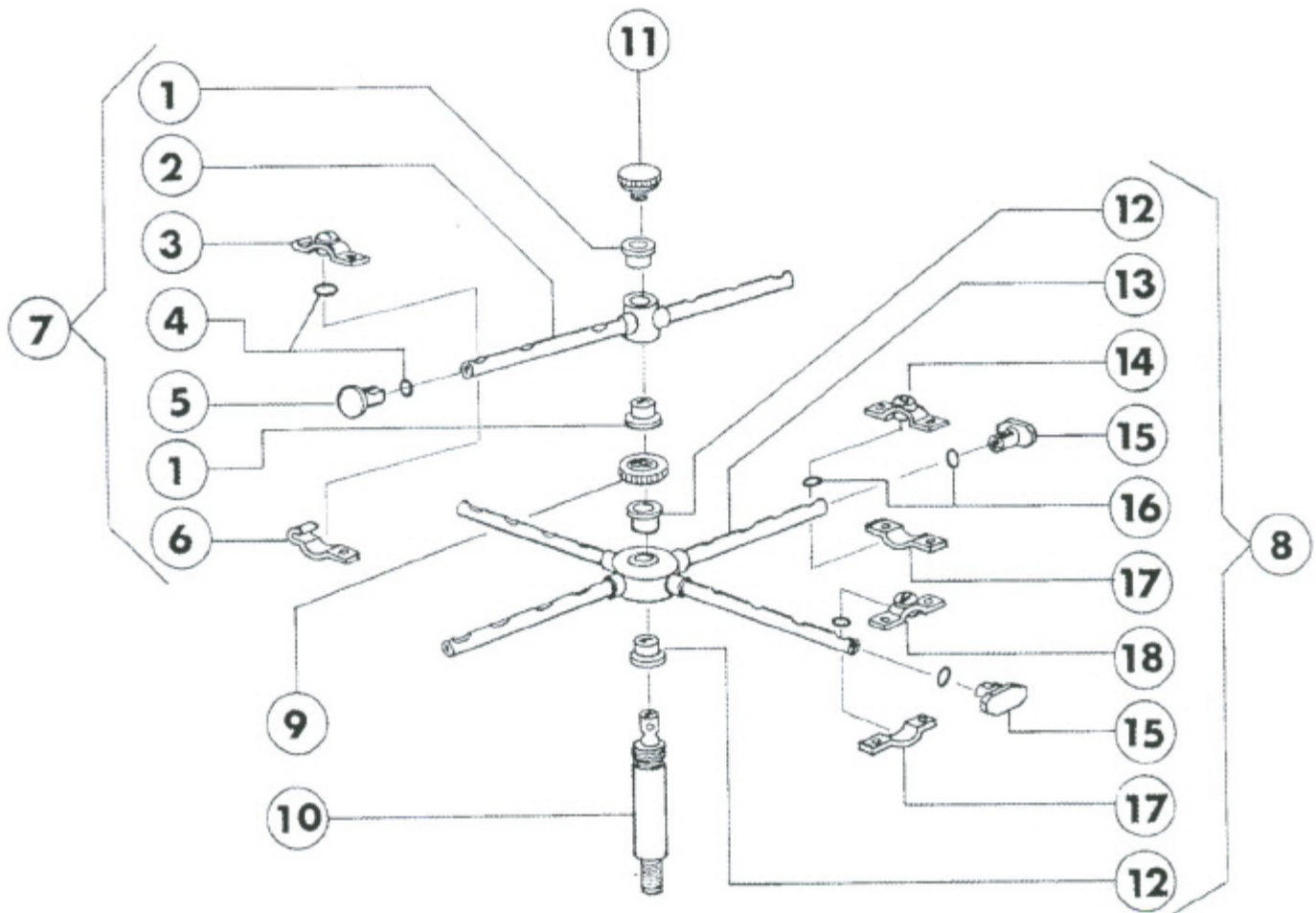

C34
Wash arm

CODE	DESCRIPTION	PRICE (Eur)
160718	PLUG F. RINSE ARM F2-C34MOPL	0.00
160719	PLUG FOR WASH ARM D.18	0.00
170704	RINSE NOZZLE BOTTOM F-B-C33	0.00
170911	RINSE JET B23-F2-C34	0.00
170917	WASH JET RIGHT C34	0.00
170918	WASH JET LEFT C34	0.00
180213	FLANGE F JET LOCKING F2-C34	0.00
190614	BUSH CENTRAL CROSS C34 /WASH	0.00
190615	BUSH CENTRAL CROSS C34/F2 ALG	0.00
200818	O-RING 1,78 X 6,75 X 10,31	0.00
200824	O-RING 1,78X12,42X15,98	0.00
261004	RETAIN.SCREW WASH-RINSE ARM(261009)	0.00
280409	RETAIN.LOCK NUT CENTR.CROSS C140	0.00
340499	SPINDLE CENTR. CROSS C34	0.00
420509	WASH ARM C33/C34	0.00
420511	WASH ARM ASSEMBLY C140	0.00
430307	RINSE ARM	0.00
430308	RINSE ARM ASSEMBLY C34 - C140	0.00

C34
Wash arm

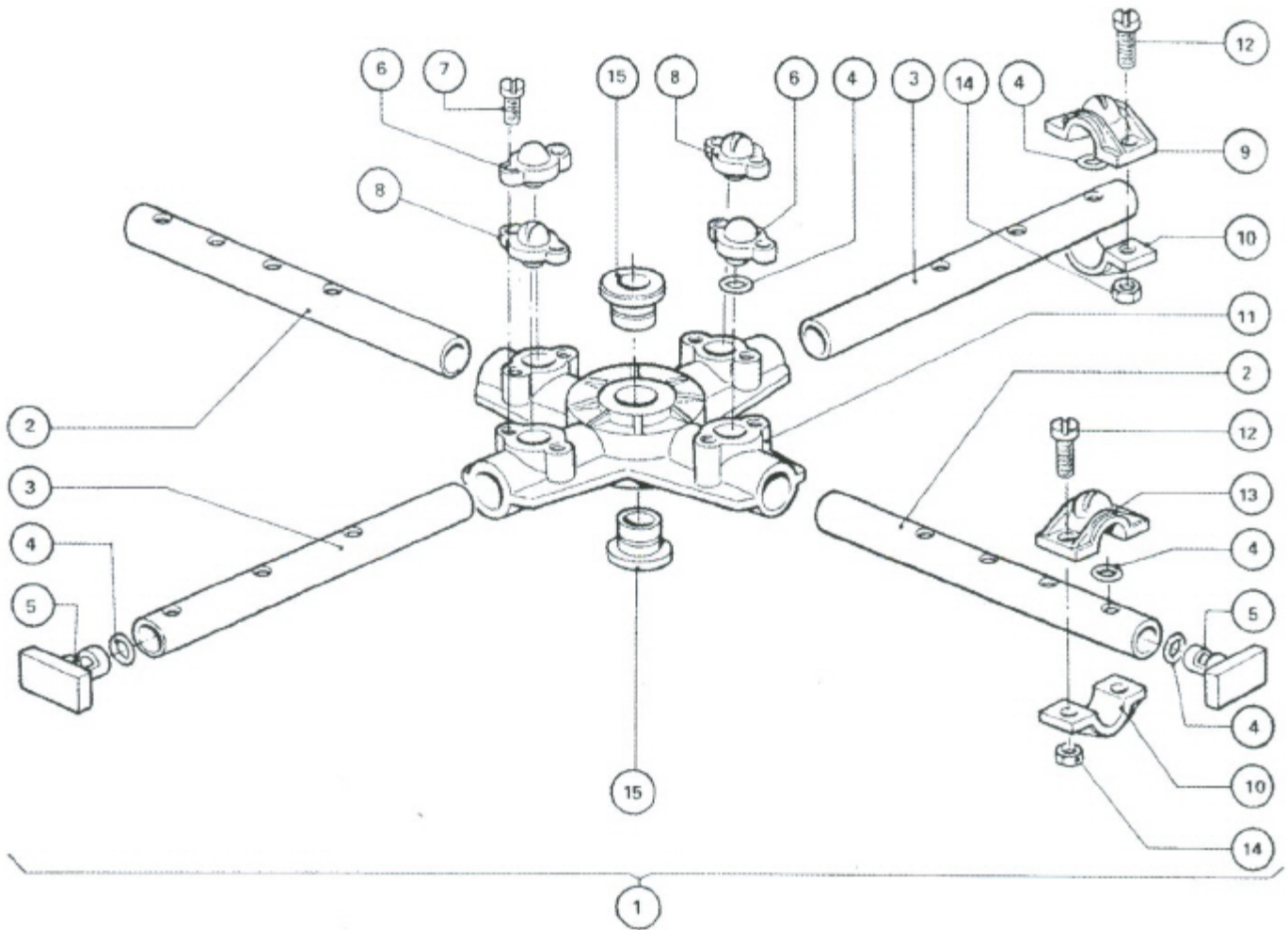

C34
Wash arm

CODE	DESCRIPTION	PRICE (Eur)
160719	PLUG FOR WASH ARM D.18	0.00
170917	WASH JET RIGHT C34	0.00
170918	WASH JET LEFT C34	0.00
170927	WASH JET F2-C-GRAY	0.00
170928	IDLE JET F2-C-GRAY	0.00
180213	FLANGE F.JET LOCKING F2-C34	0.00
190621	BUSHING CENTR.CROSS C34	0.00
191027	CENTRAL CROSS C34-140	0.00
200824	O-RING 1,78X12,42X15,98	0.00
260207	STAINL.ST TCP SCREW4X25 A2 UNI 6107	0.00
260226	STAINL.ST TCP SCREW 4X12 A2 UNI6107	0.00
260402	STAINLESS STEEL NUTS D4 UNI 5588	0.00
331359	WASHING TUBE	0.00
331360	WASHING TUBE	0.00
420511	WASH ARM ASSEMBLY C140	0.00

C34
Wash arm

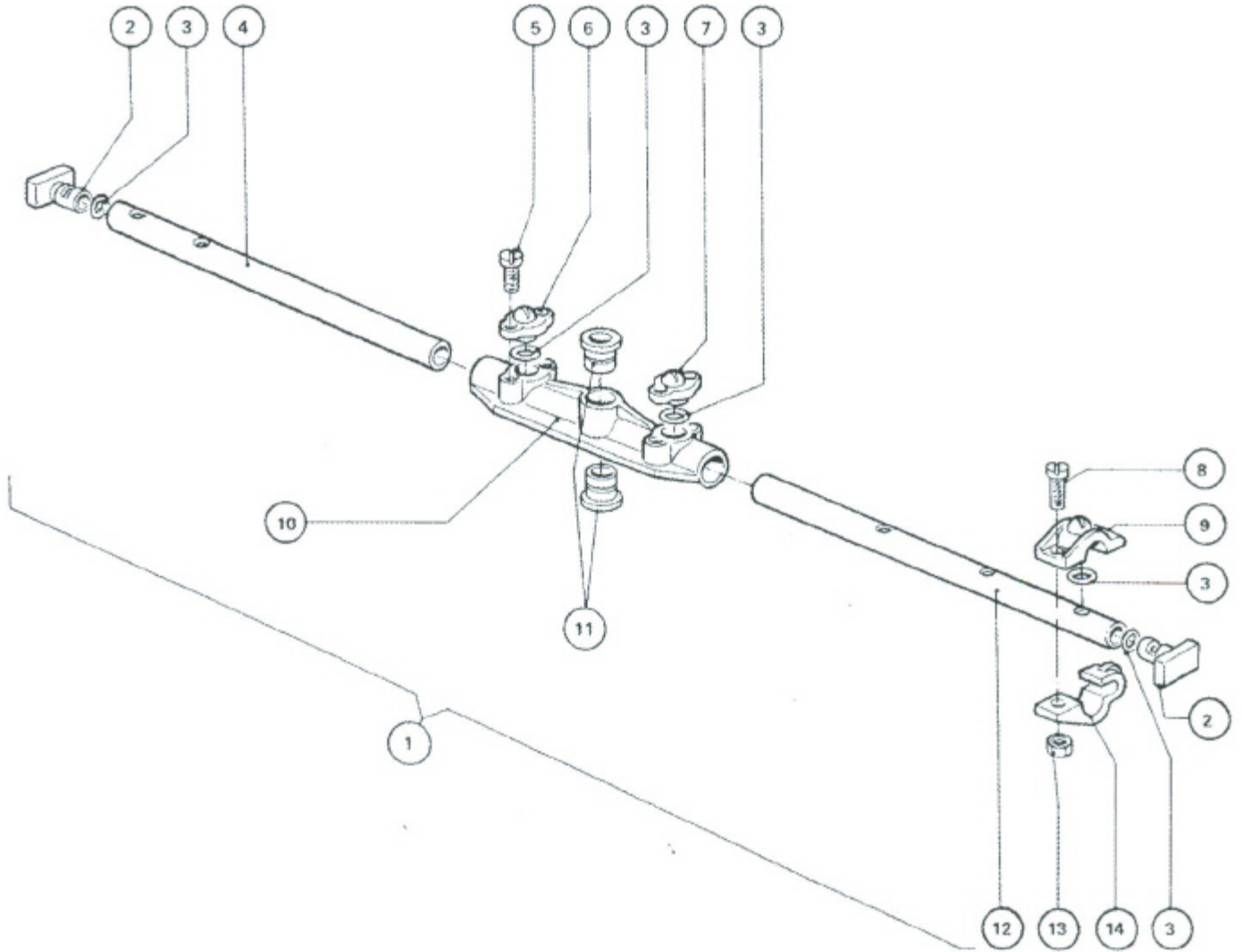

C34
Wash arm

CODE	DESCRIPTION	PRICE (Eur)
160718	PLUG F. RINSE ARM F2-C34MOPL	0.00
170704	RINSE NOZZLE BOTTOM F-B-C33	0.00
170911	RINSE JET B23-F2-C34	0.00
170929	RINSE JET F2-C-GRAY	0.00
170930	IDLE JET F2-C-GRAY	0.00
190617	BUSH	0.00
191030	CENTRAL CROSS RINSE C34-140	0.00
200818	O-RING 1,78 X 6,75 X 10,31	0.00
260207	STAINL. ST TCP SCREW4X25 A2 UNI 6107	0.00
260226	STAINL. ST TCP SCREW 4X12 A2 UNI6107	0.00
260402	STAINLESS STEEL NUTS D4 UNI 5588	0.00
331361	TUBE RINSE	0.00
331362	TUBE RINSE	0.00
420515	WASH-RINSE ARM F45-C85	0.00

C34
Control box

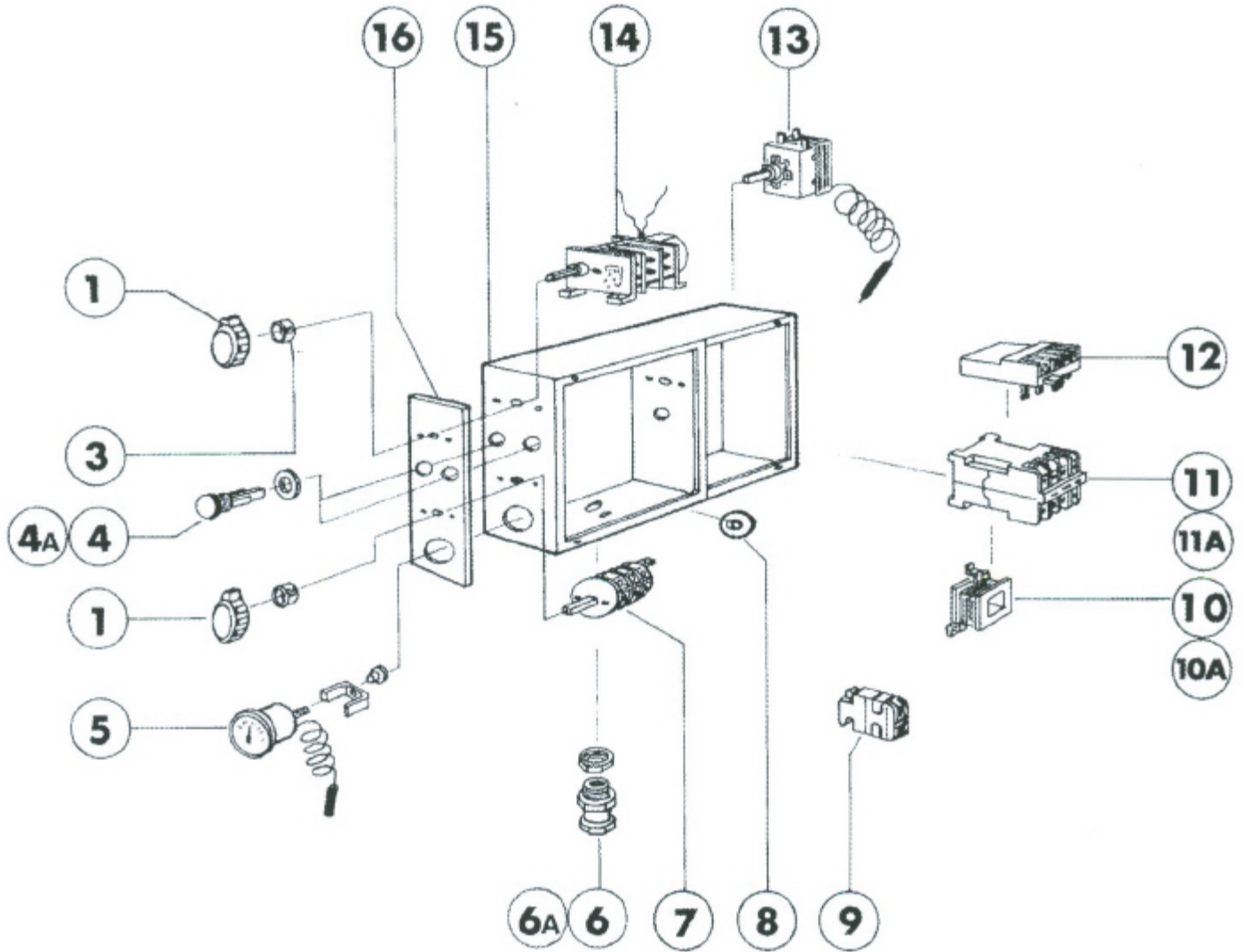

C34
Control box

CODE	DESCRIPTION	PRICE (Eur)
120208	TIMER 1G 210" 220V 50HZ	0.00
120434	CONTACTOR 9A 220V 50HZ	0.00
120435	CONTACTOR 17A 220V 50HZ	0.00
120501	THERMOSTAT 30/90° MT 1 TR/2	0.00
120712	SWITCH BIP. 16AMP B-F45	0.00
120824	OVERLOAD RELAY 4/6 A	0.00
130120	RED LIGHT 220V C34	0.00
130121	GREEN LIGHT 220V C34	0.00
150202	TERMINAL BLOCK	0.00
150805	CABLE HOLDER 18X22X1	0.00
150812	CABLE HOLDER 3/4" D.16-20 WITH NUT	0.00
150813	CABLE HOLDER 1"	0.00
180111	BLACK KNOB	0.00
321528	BOX FOR CONTROL PANEL	0.00
440817	SNAP RING LSCB/1853/17/00	0.00
450905	CAPIL.THERMOMETER D.52 1,5m	0.00
460188	CONTROL PANEL BLACK ALU C34	0.00
630954	COIL 9-12A 220V X1	0.00
630956	COIL 16A 220V	0.00

C34
Steam version

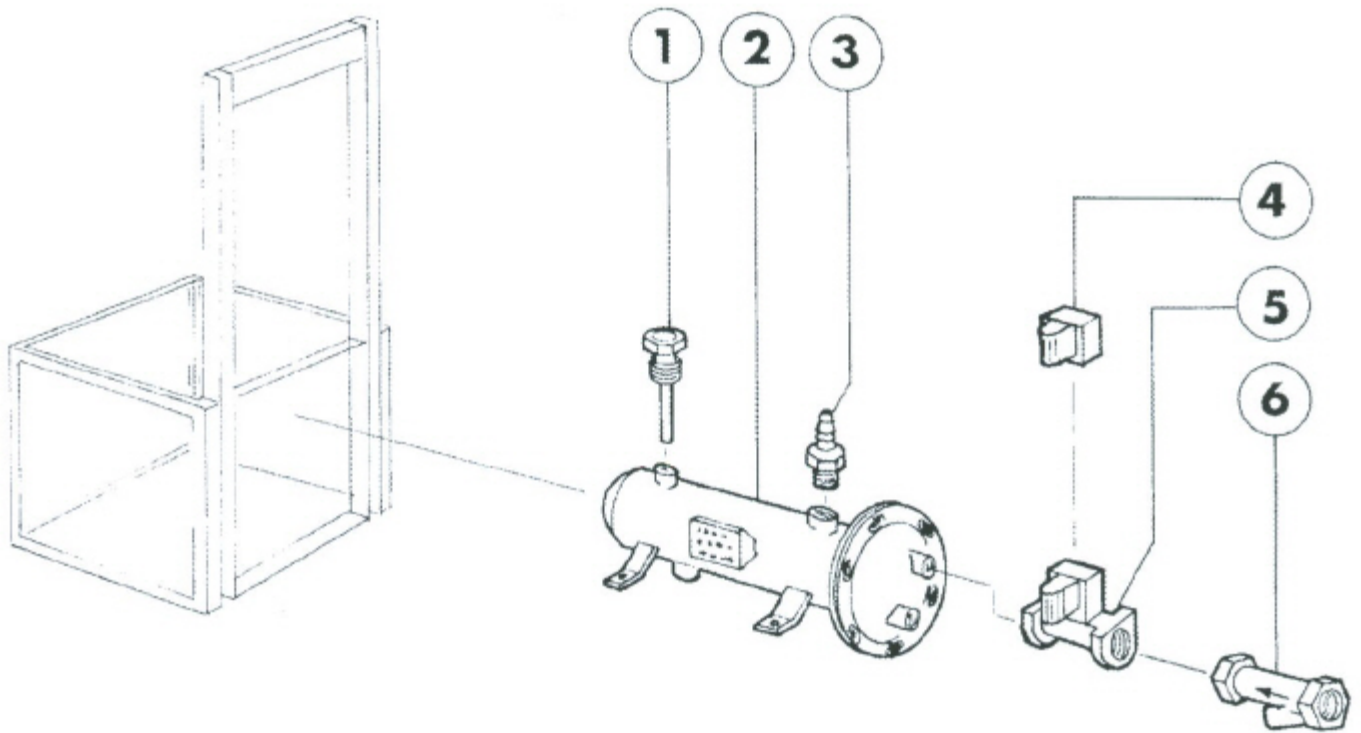

C34
Steam version

CODE	DESCRIPTION	PRICE (Eur)
120138	SOLE.N.VALVE ST.220V50HZ 3/4G L149	0.00
290410	NIPPLE 1/2"	0.00
310601	STRAINERS JU 1/2" MOD.45	0.00
330312	STEAM BOILER 6000 KCAL/H	0.00
450508	THERMOSTAT SHIELD	0.00
630949	COIL 1"-3/4" 220V L149	0.00