

I	LAVASTOVIGLIE INDUSTRIALI
F	LAVE-VAISSELLE INDUSTRIELS
GB	INDUSTRIAL DISHWASHER
D	INDUSTRIEGESCHIRRSPÜLER
ES	LAVAVAJILLAS INDUSTRIALES

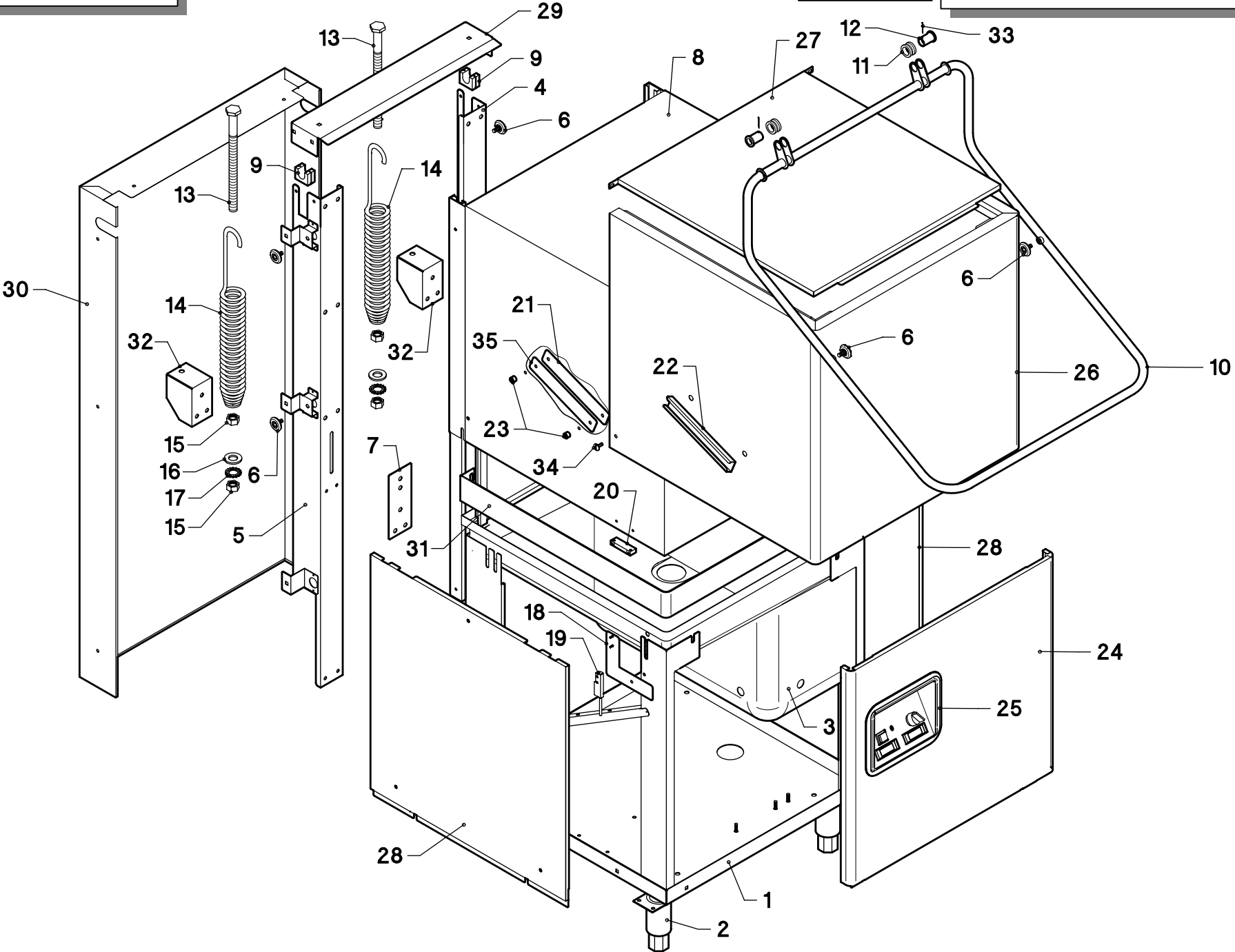

**N1300**

 <b>SILANOS</b> <sup>®</sup> LAVASTOVIGLIE INDUSTRIALI	MANUALE PARTI DI RICAMBIO	
	CATALOGUES PIÉCES DETACHEES	
	SPARE PARTS MANUAL	
	ERSATZTEILEKATALOG	
Rev. 12-2005	Cod. 201314	MANUAL PARTES DE REPUESTOS



Pos.	COD.	Q.tà	DESCRIZIONE	DENOMINATION	DESCRIPTION	BEZEICHNUNG	DESCRIPCIÓN
1	908501	1	BASAMENTO	SOCLE	BASE	UNTERSTRUKTUR	BASE
2	TR0860	4	PIEDINO REGOLABILE	PETIT PIED RÉGABLE	RUBBER LEG	EINSTELLBARESOCKEL	PIÉ REGULABLE
3	908571	1	VASCA STAMPATA	BASSIN	TANK	WANNE	BATEA
4	908508	1	LONGHERONE DX	LONGERON	BACK STAY	LANGSTRAGER	LARGUERO DX
5	908509	1	LONGHERONE SX	LONGERON	BACK STAY	LANGSTRAGER	LARGUERO SX
6	908704	8	CUSCINETTO CON PERNO	ROULEMENT	BEARING	LAGER	COJINETE
7	950315	2	SPESSORE X LONGHERONE	ÉPAISSEUR	THICKNESS	STÄRKE	GRUESO
8	908513	1	CAPOTE COMPLETA	CAPOTE	HOOD	GEHAUSE	CAPOTE
9	908703	2	BUSSOLA PER MANIGLIONE	DOUILLE	BEARING	BUCHSE	BRÚJULA
10	909046	1	MANIGLIONE COMPLETO	POIGNEE	HANDLE	HANDRIFF	MANIJA
11	906066	2	ROTELLA SUPPORTO MOLLA	GALET PIVOTANT	SMALL WHELL	RADCHEN	RUEDA DE SOPORTE RESORTE
12	904796	2	PERNO ROTELLA	PIVOT D'ACCROCHAGE	HOOKING PIN	KUPPLUNGSBOLZEN	PERNO
13	902377	2	TIRANTE MOLLA	TIRANT	CONNECTING ROD	ZUGSTAB	VARILLA RESORTE
14	904137	2	MOLLA SOLLEV. CAPOTE	RESSORT	SPRING	FEDER	RESORTE
15	902035	4	DADO M10 TORN.	ECROU	NUT	MUTTER	TUERCA
16	906055	2	RONDELLA PIANA Ø10	RONDELLE	WASHER	UNTERLEGSCHIEBE	ARANDELA
17	905941	2	RONDELLA GROWER Ø10	RONDELLE	WASHER	UNTERLEGSCHIEBE	ARANDELA GROWER
18	908504	1	SUPPORTO MICRO	SUPPORT MICRO	SUPPORT MICRO	HALTERUNG MIKRO	SOPORTE MICRO
19	909105	1	REED MAGNETICO	REED	REED	REED	REED MAGNÉTICO
20	908706	1	CUSTODIA CON MAGNETE	PROTECTION MAGNETO	COVER MAGNET	MAGNETSCHUTZ	ESTUCHE CON IMÁN
21	908512	2	PIASTRA FISSAGGIO GUIDA	PLAQUE FIXATION GUIDE	PLATE FIXING GUIDES	PLATTE BEFESTIGUNG FÜHRT	PLACA FIJADO GUÍAS
22	908511	2	GUIDA MANIGLIONE	GUIDE DE POIGNÉE	HANDLE GUIDE	HANDGRIFF-FÜHRER	GUÍA DE LA MANIJA
23	908726	4	DISTANZIALE CAPOTE	ENTRETOISE	SPACER	DISTANZSCHEIBE	ESPACIADOR
24	908650	1	COBENTAZIONE FRONTALE VASCA	ISOLATION FRONTALE	FRONTAL INSULATING	FRONTALES ISOLIEREN	AISLAMIENTO FRONTAL
25	908657	1	RETROTARGA	PLAQUETTE	PLATE	SCHILD	PLACA
26	908653	1	COBENTAZIONE CAPOTE	ISOLATION CAPOTE	HOOD INSULATING	GEHAUSE ISOLIEREN	AISLAMIENTO CAPOTE
27	908654	1	CAPPELLO COBENTAZIONE CAPOTE	COUVERCLE ISOLATION CAPOTE	HOOD INSULATING COVER	GEHASE ISOLIEREN DECKEL	COBERTURA AISLAMIENTO CAPOTE
28	908652	2	COBENTAZIONE LATERALE DX-SX	ISOLATION LATÉRALE	LATERAL INSULATING	SEITLICHES ISOLIEREN	AISLAMIENTO LATERAL
29	908510	1	TRAVERSA POSTER. SUPERIORE	ENTRETOISE POSTER. SUPÉRIEUR	UPPER BACK CROSSPIECE	OBERER HINTERE DURCHQUERUNG	TRAVESÍA POSTERIOR SUPERIOR
30	908655	1	PANNELLO POSTERIORE	PANNEAU POSTERIEUR	BACK PANEL	HINTERE VERKLEIDUNG	PANEL POSTERIOR
31	908649	1	COBENTAZIONE SUPERIORE VASCA	ISOLATION SUPÉRIEUR BASSIN	UPPER BACK INSULATING TANK	OBERER ISOLIEREN WANNE	AISLAMIENTO SUPERIOR BATEA
32	950316	2	SUPPORTO TIRAGGIO MOLLE	SUPPORT RESSORT	SPRINGS SUPPORT	FRÜHLINGE UNTERSTÜTZUNG	SOPORTE RESORTE
33	907773	2	COPIGLIA 2x30	COUPILLE	SPLIT PIN	SPLINT	CLAVIJA
34	907785	2	VITE FEMMINA M6	VIS	SCREW	SCHRAUBE	TORNILLO

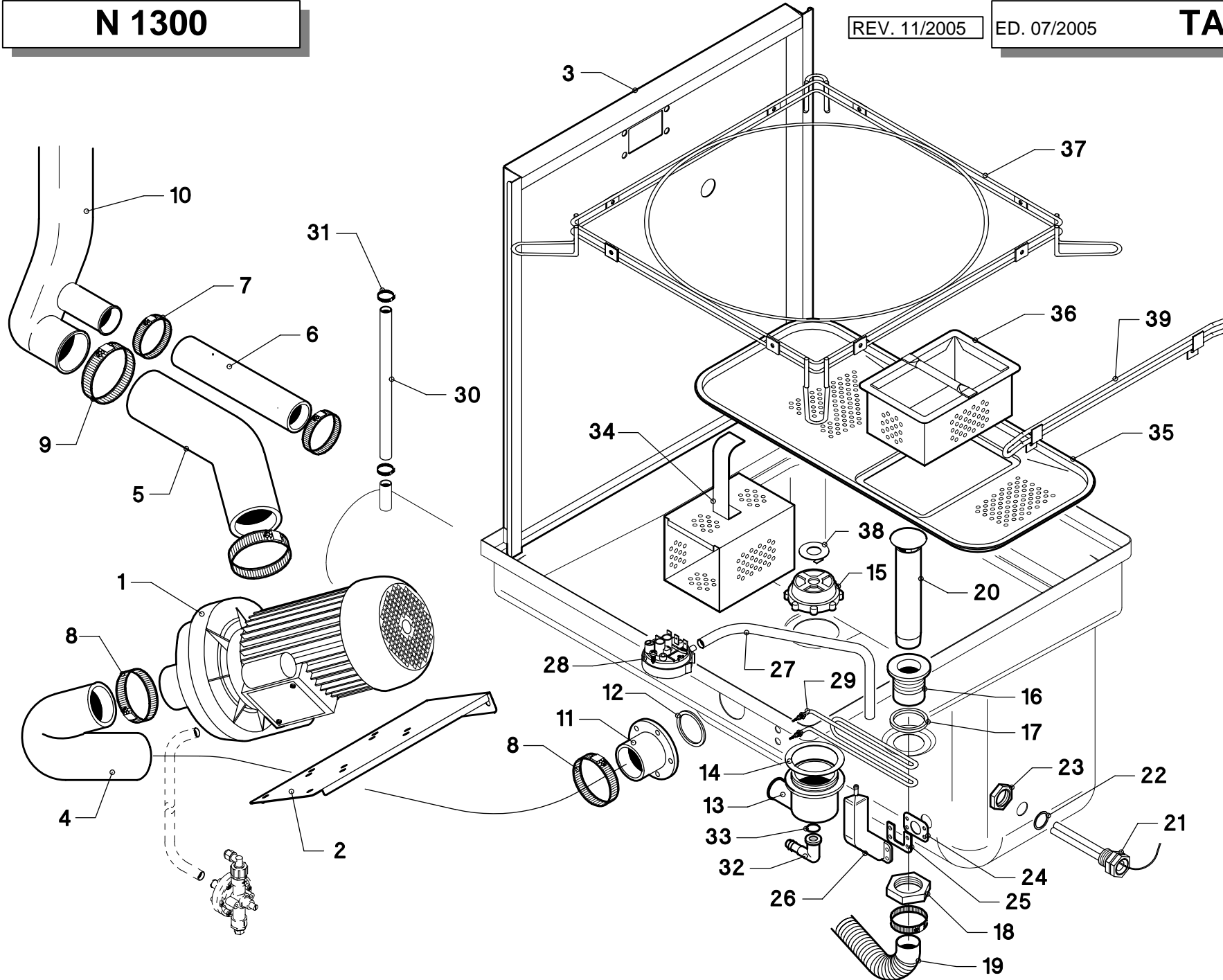

Pos.	COD.	Q.tà	DESCRIZIONE	DENOMINATION	DESCRIPTION	BEZEICHNUNG	DESCRIPCIÓN
1	909077	1	POMPA	POMPE	PUMP	PUMPE	BOMBA
2	908574	1	SUPPORTO POMPA	SUPPORT POMPE	PUMP SUPPORT	PUMPE TRÄGER	SOPORTE BOMBA
3	908516	1	SCHIENALE	STRUCURE POSTERIEUR	BACK FRAME WORK	GEFÜGE	RESPALDO
4	903701	1	MANICOTTO ASPIRAZIONE	MANCHON D'ASPIRATION	INLET ELBOW	ANSAUGMUFFE	PALANCA DE ASPIRACIÓN
5	908713	1	TUBO MANDATA	MANCHON DE REFAULEM.	OUTLET ELBOW	AUSLAMUFFE	PALANCA DE MANDO
6	908712	1	TUBO MANDATA LAVAGGIO INFER.	TUYAU DE LAVAGE INF.	LOWER WASHING PIPE	UNTERER SPÜLUNG SAÜLE	TUBO LAVADO INFERIOR
7	902441	2	FASCETTA Ø 38÷50	COLLIER	CLAMP	SHELLE	ABRAZADERA
8	902490	2	FASCETTA Ø 58÷75	COLLIER	CLAMP	SHELLE	ABRAZADERA
9	902480	2	FASCETTA Ø 44÷56	COLLIER	CLAMP	SHELLE	ABRAZADERA
10	908747	1	COLONNA LAVAGGIO	COLONNE DE LAVAGE	WASHING PIPE	SPÜLUNG SAÜLE	COLUMNA LAVADO
11	901653	1	RACCORDO ASPIRAZIONE	RACCORD D'ASPIRATION	INTAKE PIPE FITTING	ANSAUGANSCHLUSSE	EMPALME DE ASPIRACIÓN
12	904395	1	O-RING	O-RING	O-RING	O-RING	O-RING
13	900049	1	MOZZO INFERIORE	MOYEU INFERIEUR	LOWER HUB	UNTERENABE	BUJE INFERIOR
14	TR2448	1	GUARNIZIONE	JOINT	GASKET	DICHTUNG	GUARNICIÓN
15	900050	1	GHIERA 2" ¼ GAS	VIROLE	LOCK-NUT	NUT MUTTER	ABRAZADERA
16	905450	1	RACCORDO SCARICO	RACCORD DÉCHARGÉ	PIPE FITTING FOR OUTLET	ABLAUFANSCHLUSS	EMPALME DESAGOTE
17	904380	1	O-RING	O-RING	O-RING	O-RING	O-RING
18	902080	1	GHIERA 1" ¼ GAS	VIROLE	LOCK-NUT	NUT MUTTER	ABRAZADERA
19	907451	1	TUBO DI SCARICO	TUYAU DE DÉCHARGÉ	OUTLET HOSE	ABLAUFSCHLAUCH	TUBO DESAGOTE
20	907338	1	TROPPO PIENO	NIVEAU	OVER FLOW	VEBERLAUF	DAMISIADO LLENO
21	TR0298	1	PORTABULBO	SIEGE DE BULBE	SEATING BULB	KUGEL SITZ	PORTABULBO
22	903250	1	GUARNIZIONE 1/2" GAS	JOINT	GASKET	DICHTUNG	GUARNICIÓN
23	902061	1	GHIERA 1/2" GAS	VIROLE	LOCK NUT	NUT MUTTER	ABRAZADERA
24	903261	1	GUARNIZIONE TRAPPOLA ARIA	JOINT RESERVOIR AIR	AIR TRAP GASKET	DICHTUNG LUFTFALLE	GUARNICIÓN TRAMPA DEL AIRE
25	907926	1	PIASTRINA TRAPPOLA ARIA	PLAQUETTE RESERVOIR AIR	AIR TRAP LINK	GLIED LUFTFALLE	PLANCHA TRAMPA DEL AIRE
26	907254	1	TRAPPOLA ARIA	RESERVOIR AIR	AIR TRAP	LUFTFALLE	TRAMPA DEL AIRE
27	907279	1	TUBO PRESSOSTATO	TUYAU PRESSOSTAT	PRESSURE SWITCH PIPE	SCHLAUCH	TUBO PRESÓSTATO
28	905282	1	PRESSOSTATO	PRESSOSTAT	PRESSURE SWITCH	DRUCHWAECHTE	PRESOSTATO
29	905748	1	RESISTENZA 3000W	RESISTANCE	HEATING ELEMENT	HEIZKÖRPER	RESISTENCIA
30	907295	1	TUBO GOMMA 12 x 19,5	TUYAU EN CAOUTCHOUC	RUBBER HOSE	GUMMISCHLAUCH	TUBO GOMA
31	902440	3	FASCETTA Ø 13÷20	COLLIER	CLAMP	SHELLE	ABRAZADERA
32	905453	1	RACCORDO A GOMITO	RACCORD	PIPE FITTING	ANSCHLUSS	EMPALME A CODO
33	903351	1	GUARNIZIONE	JOINT	GASKET	DICHTUNG	GUARNICIÓN
34	906710	1	FILTRO ASPIRAZIONE VASCA	FILTRE D'ASPIRATION	INTAKE FILTER	ABLAUF FILTER	FILTRO DE ASPIRACIÓN
35	906703	1	FILTRO VASCA	FILTRE BASSIN	TANK FILTER	FILTER WANNE	FILTRO BATEA
36	906704	1	FILTRO A CASSETTO	TIROIR FILTRE	DRAWER FILTER	FACH-FILTER	FILTRO A CAJÓN
37	908708	1	TELAIO PORTACESTELLI	CHASSIS PORTE PANIER	TRACK	FÜHRUNG	BASTIDOR
38	906001	1	RONDELLA RIDUZIONE	RONDELLE DE RÉDUCTION	REDUCTION WASHER	VERKLEINERUNG UNTERLEGSCHIBE	ARANDELA DE REDUCCIÓN
39	901672	1	GUIDA PORTACESTELLO	COULISSE PANIER	BASKET GUIDE	KORBÜFHRUNG	GUIA CANASTOS

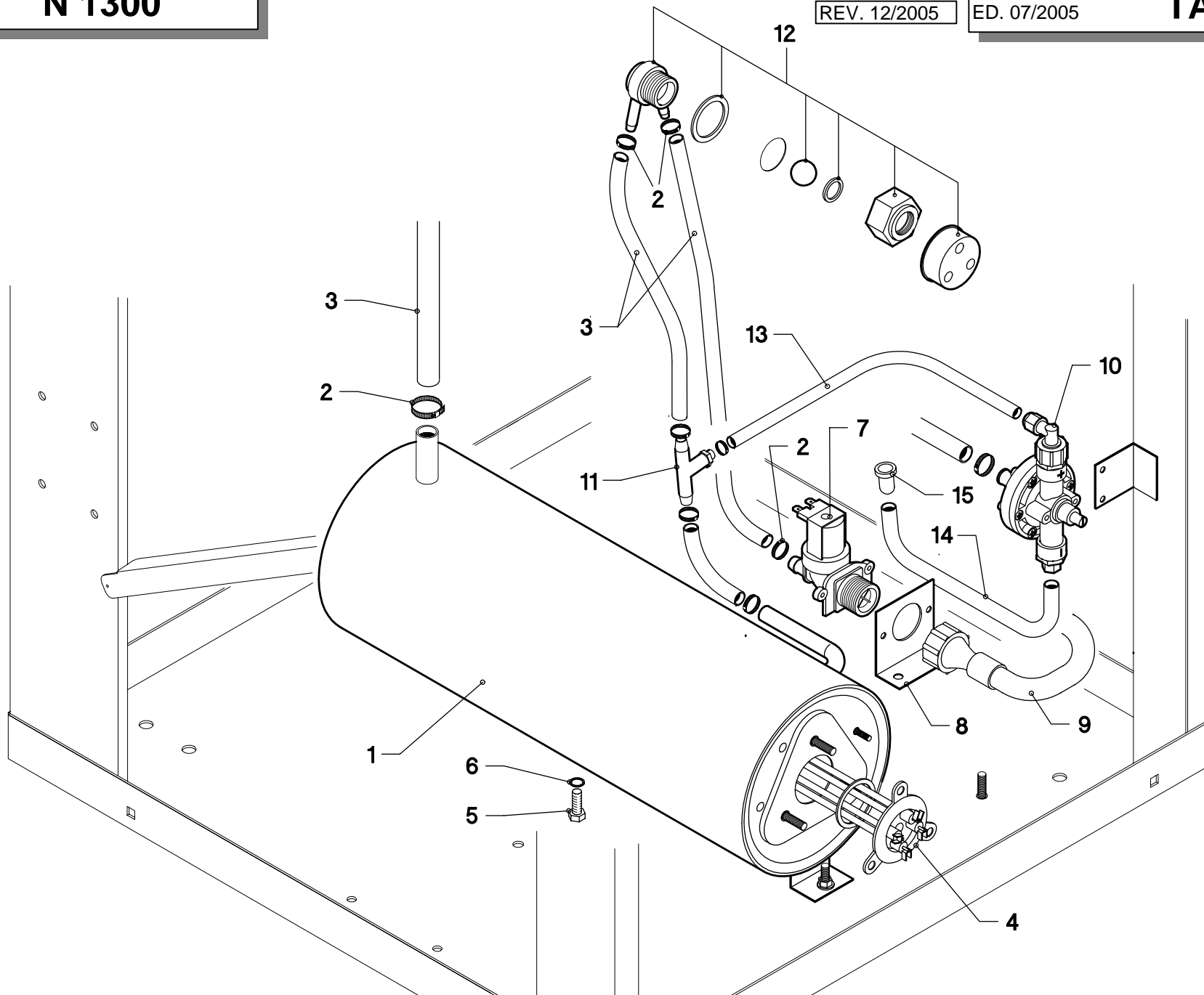

**N 1300**

REV. 12/2005

ED. 07/2005

**TAV. 3**

<b>Pos.</b>	<b>COD.</b>	<b>Q.tà</b>	<b>DESCRIZIONE</b>	<b>DENOMINATION</b>	<b>DESCRIPTION</b>	<b>BEZEICHNUNG</b>	<b>DESCRIPCIÓN</b>
1	900485	1	BOILER	CHAUFFE EAU	BOILER	HEISSWASSERSPEICHER	BOILER
2	902440	7	FASCETTA Ø 13÷20	COLLIER	CLAMP	SHELLE	ABRAZADERA
3	907295	4	TUBO GOMMA 12x19,5	TUYAU EN CAOUTCHOUC	RUBBER HOSE	GUMMISCHLAUCH	TUBO GOMA
4	905570	1	RESISTENZA 6KW + O-RING	RESISTANCE + O-RING	HEATING ELEMENT + O-RING	HEIZKÖRPER + O-RING	RESISTENCIA + O-RING
5	907820	1	VITE	VIS	SCREW	SCHRAUBE	TORNILLO
6	904430	1	O-RING TAPPO BOILER	O-RING BOUCHON	O-RING PLUG	O-RING FROPFEN	O-RING TAPÓN
7	902390	1	ELETTRIVALVOLA	SOUPAPE ELECTRIQUE	ELECTRIC VALVE	ELEKTROVENTIL	VALVULA ELETRICA
8	906365	1	SUPPORTO ELETTRIVALVOLA	PALIER SOUPAPE ELECTRIQUE	BEARING ELECTRIC VALVE	TRÄGE ELEKTROVENTIL	SOPORTO VALVULA ELETRICA
9	907345	1	TUBO CARICO ACQUA	TUYAN D'ENTRÉE DE L'EAU	INLET PIPE	WASSERZUFÜHRROHR	TUBO
10	902018	1	DOSATORE POMPA	DOSEUR POMPE	PUMP DOSING DEVICE	DOSIERSATZ PUMPE	DOSIFICADOR BOMBA
11	905408	1	RACCORDO A 3 VIE	RACCORD	PIPE FITTING	ANSCHLUSSE	EMPALME
12	TR2433	1	VALVOLA ANTIRIFLUSSO	VALVE	VALVE	VENTIL	VALVULA
13	907279	1	TUBO 4 x 7	TUYAU	PIPE	SCHLAUCH	TUBO
14	907278	1	TUBO 4 x 7	TUYAU	PIPE	SCHLAUCH	TUBO
15	902568	1	FILTRO DOSATORE	FILTRE DOSEUR	FILTER FOR DOSING	FILTER	FILTRO DOSIFICADOR

**TAV. 4**

ED. 07/2005

REV. 12/2005

**N 1300**

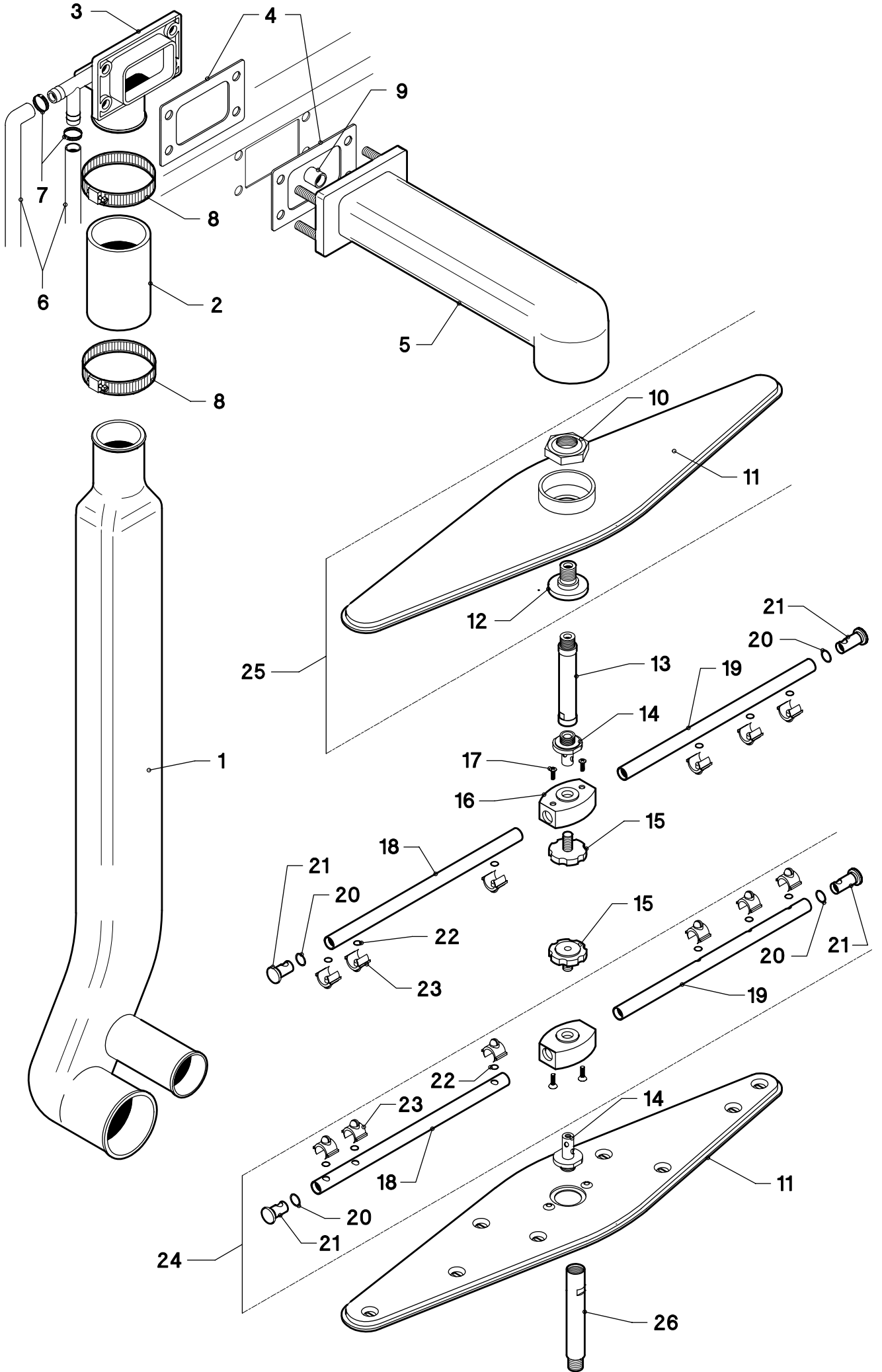

**N 1300**

REV. 12/2005

ED. 07/2005

**TAV. 4**

Pos.	COD.	Q.tà	DESCRIZIONE	DENOMINATION	DESCRIPTION	BEZEICHNUNG	DESCRIPCIÓN
1	908747	1	COLONNA LAVAGGIO	COLONNE DE LAVAGE	WASHING PIPE	SPÜLÜNG SAÜLE	COLUMNA LAVADO
2	903706	1	MANICOTTO	MANCHON	ELBOW	MUFFE	PALANCA
3	908745	1	RACCORDO BRACCIO	RACCORD	PIPE FITTING	ANSCHLUSSE	EMPALME
4	903413	2	GUARNIZIONE COLONNA LAVAGGIO	JOINT COLONNE DE LAVAGE	WASHING PIPE GASKET	SPÜLÜNG SAÜLE DICHTUNG	GUARNICIÓN COLUMNA LAVADO
5	908744	1	BRACCIO LAVAGGIO	BRAS DE LAVAGE	WASHING ARM	WASCHLAUFRAD	BRAZO LAVADO
6	907295	2	TUBO GOMMA 12 x 19,5	TUYAU EN CAOUTCHOUC	RUBBER HOSE	GUMMISCHLAUCH	TUBO GOMA
7	902440	2	FASCETTA Ø 13-20	COLLIER	CLAMP	SHELLE	ABRAZADERA
8	902480	2	FASCETTA Ø 44-56	COLLIER	CLAMP	SHELLE	ABRAZADERA
9	903379	1	GUARNIZIONE	JOINT	GASKET	DICHTUNG	GUARNICIÓN
10	902890	2	GHIERA BLOCCAGGIO	FRETTE DE BLOCAGE	RING-NUT	KLEMMUTTER	ABRAZADERA BLOQUEO
11	902960	2	GIRANTE LAVAGGIO	BRAS DE LAVAGE	WASH ARM	SPÜLLARM	RODETE LAVADO
12	902891	2	MOZZO GIRANTE LAVAGGIO	MOYEU	HUB	NABE	BUJE RODETE LAVADO
13	904751	1	PERNO RISCIA SCUO SUPERIORE	TOURILLON DE RINÇAGE SUPER.	UPPER RINSE PIN	OBERER SPÜLLSTIFT	PERNO ENJUAGUE SUPERIOR
14	904760	2	PERNO RISCIA SCUO	TOURILLON DE RINÇAGE	RINSE PIN	SPÜLLSTIFT	PERNO ENJUAGUE
15	902880	2	GHIERA BLOCCAGGIO	FRETTE DE BLOCAGE	RING-NUT	KLEMMUTTER	ABRAZADERA BLOQUEO
16	904292	2	MOZZO GIRANTE RISCIA SCUO	MOYEU	HUB	NABE	BUJE RODETE ENJUAGUE
17	907651	4	VITE TPS M 4x8	VIS	SCREW	SCHRAUBE	TORNILLO
18	954806	2	BRACCIO RISCIA SCUO DX	BRAS DE RINÇAGE DROITE	RIGHT RINSE ARM	RECHTE SPÜLLAUFRAD	BRAZO ENJUAGUE DERECHO
19	954807	2	BRACCIO RISCIA SCUO SX	BRAS DE RINÇAGE GAUCHE	LEFT RINSE ARM	LINKE SPÜLLAUFRAD	BRAZO ENJUAGUE IZQUIERDO
20	904321	4	O-RING	O-RING	O-RING	O-RING	O-RING
21	906450	4	TAPPO PER BRACCIO RISCIA SCUO	BOUCHON BRAS DE RINÇAGE	PLUG FOR RINSE ARM	VERSCHLUSS SPÜLLAUF	TAPÓN PARA BRAZO ENJUAGUE
22	904388	12	O-RING	O-RING	O-RING	O-RING	O-RING
23	902816	12	GETTO RISCIA SCUO	JET DE RINÇAGE	RINSING JET	SPÜLLDUSE	CHORRO ENJUAGUE
24	903017	2	GIRANTE RISCIA SCUO COMP.	BRAS DE RINÇAGE COMPL.	COMPL. RINSE ARM	SPÜLLSTIFT KOMPL.	RODETE ENJUAGUE COMP.
25	902961	2	GIRANTE LAVAGGIO COMP.	BRAS DE LAVAGE COMPL.	COMPL. WASH ARM	SPÜLLARM KOMPL.	RODETE LAVADO COMPL.
26	904753	1	PERNO RISCIA SCUO INFERIORE	TOURILLON DE RINÇAGE INFER.	INFERIOR RINSE PIN	UNTERS PÜLLSTIFT	PERNO ENJUAGUE INFERIOR

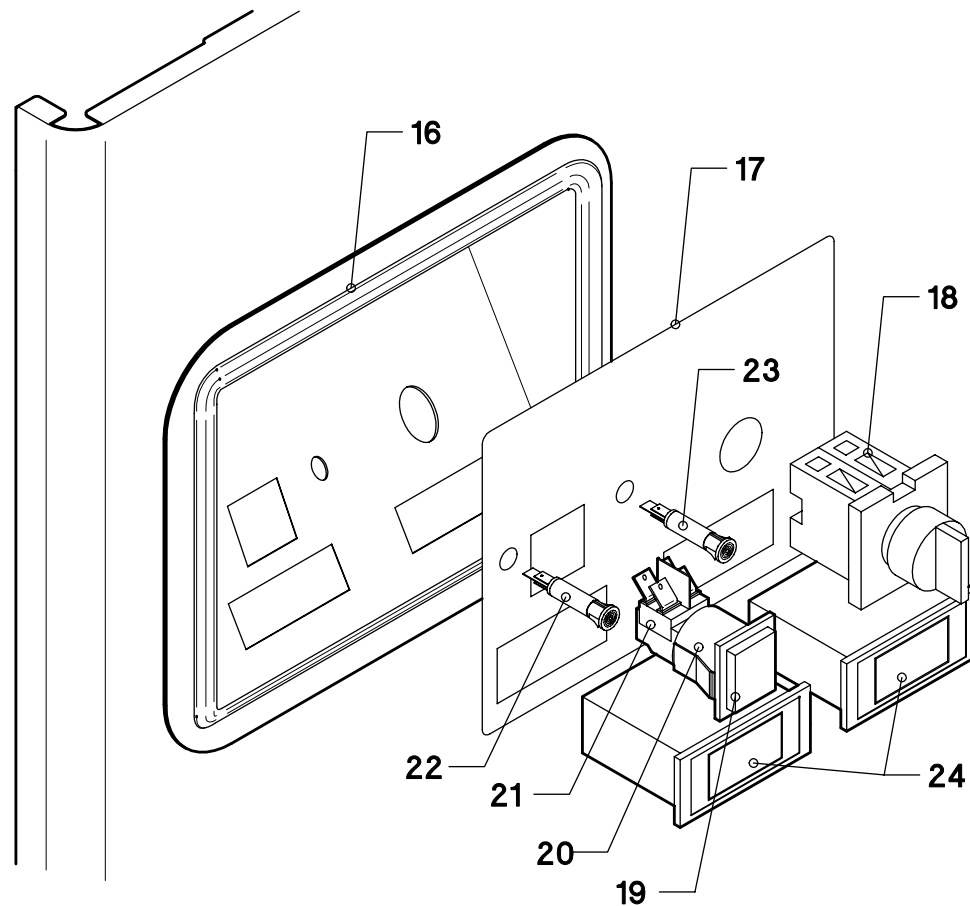
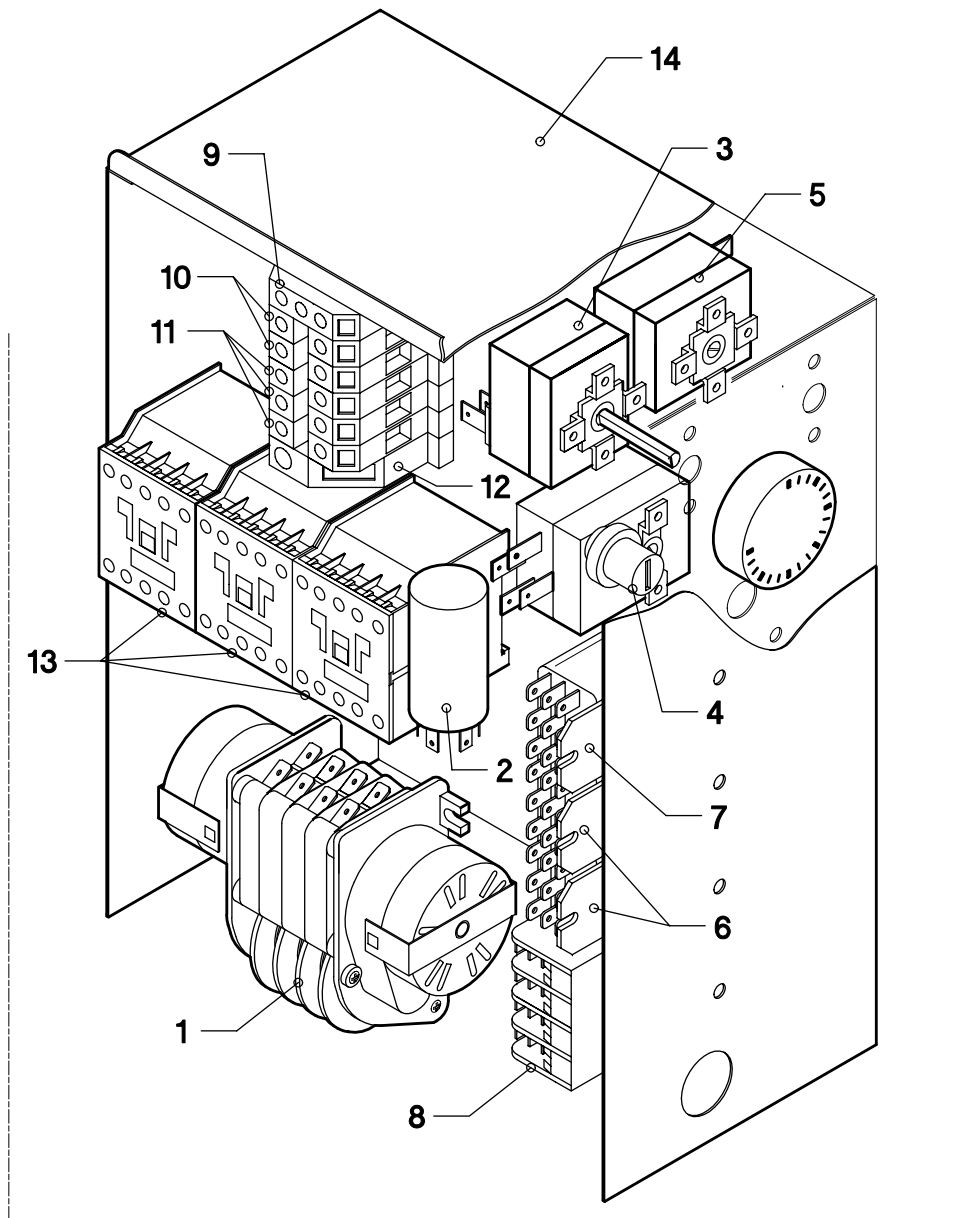

**N 1300**

REV. 12/2005

ED. 07/2005

**TAV. 5**

<b>Pos.</b>	<b>COD.</b>	<b>Q.tà</b>	<b>DESCRIZIONE</b>	<b>DENOMINATION</b>	<b>DESCRIPTION</b>	<b>BEZEICHNUNG</b>	<b>DESCRIPCIÓN</b>
1	907183	1	TIMER	TIMER	TIMER	TIMER	TIMER
2	902107	1	FILTRI ANTIDISTURBO	FILTRE ANTIDERANGEMENT	NOISE FILTER	ENTSTORFILTER	FILTROS DE RUIDOSIDAD
3	907110	1	TERMOSTATO 0°-90°	THERMOSTAT	THERMOSTAT	THERMOSTAT	TERMÓSTATO
4	907125	1	TERMOSTATO DI SICUREZZA	THERMOSTAT	THERMOSTAT	THERMOSTAT	TERMÓSTATO DE SEGURIDAD
5	907120	1	TERMOSTATO 55°	THERMOSTAT	THERMOSTAT	THERMOSTAT	TERMÓSTATO
6	905476	2	RELÉ	RELAIS	RELAY	RELAIS	RELÉ
7	905475	1	RELÉ	RELAIS	RELAY	RELAIS	RELÉ
8	955068	4	MORSETTO PA80	BORNE	TERMINAL	KLEMMLEISTE	GRAMPA
9	904163	1	MORSETTO TERRA	BORNE	TERMINAL	KLEMMLEISTE	GRAMPA TIERRA
10	TR3178	2	MORSETTO 3P	BORNE	TERMINAL	KLEMMLEISTE	GRAMPA
11	904166	3	MORSETTO 1P	BORNE	TERMINAL	KLEMMLEISTE	GRAMPA
12	904175	1	FERMA MORSETTO	ARRÊTÉE BORNE	TERMINAL BLOCK	KLEMMENBLOCK	BLOQUE GRAMPA
13	907095	3	TELERUTTORE 9A	TELERUPTEUR	CONTACTOR	SCHUTZ	TELERRUPTOR
14	908752	1	CASSETTA ELETTRICA	BOITE ELECTRIQUE	CABINET	SCHALTKASTEN	CAJA ELÉCTRICA
15	902367	1	QUADRO ELETTRICO	TABLEAU ELECTRIQUE	SWITCHBOARD	SCHALTAFEL	TABLERO ELÉCTRICO
16	955646	1	RETROTARGA	PLAQUETTE	PLATE	SCHILD	PLACA
17	907064	1	TARGA	PLAQUETTE	PLATE	SCHILD	PLACA
18	TR0850	1	INTERRUTTORE 0 - 1 - 2	INTERRUPTEUR	SWITCH	DRUCKKNOPF	INTERRUPTOR
19	905308	1	PULSANTE QUADRO GIALLO	BOUTON JAUNE	YELLOW PUSH-BUTTON	GELBE DRUCKTASTE	BOTÓN AMARILLO
20	905309	1	SUPPORTO TASTO	SUPPORT BOUTON	SUPPORT KEY	TASTEHALTER	SOPORTE TECLA
21	905318	1	INTERRUTTORE ON/OFF	INTERRUPTEUR	SWITCH	DRUCKKNOPF	INTERRUPTOR
22	903632	1	LAMPADA SPIA VERDE	LAMPE	LAMP	KONTROLLAMPE	LÁMPARA
23	903629	1	LAMPADA SPIA ARANCIO	LAMPE	LAMP	KONTROLLAMPE	LÁMPARA
24	907090	2	TERMOMETRO	THERMOMETRE	THERMOMETER	THERMOMETER	TERMÓMETRO